

This print is an example of an o/w separator and is not designed for specific performance ratings. Openings can be modified for specific project requirements.



Oldcastle Precast[®]

OW-1500

FILE NAME: 324ECO0W-1500_ISO.DWG

ISSUE DATE: January, 2008

www.oldcastleprecast.com

5'-0" x 10'-0" x 5'-1" I.D.
Oil/Water Separator
1,500 Gallon Capacity

Copyright © 2008 **Oldcastle Precast**[®]

NOTES:

1. Concrete: 5,000 P.S.I.
Minimum Strength @ 28 Days
2. Steel Reinforcement— ASTM A-615,
Grade 60.
3. Cover to Steel—1" Minimum
4. Tanks are Designed to Meet
ASTM C858 and ACI 318
with AASHTO HS-20 Loading
5. Earth Cover—0 to 5 Feet
Minimum
6. Construction Joint—Sealed with
1" Dia. Butyl Rubber or Equivalent
7. Approx. Wt. Top Pc. = 5.4 Tons
Approx. Wt. Bottom Pc. = 5.7 Tons
8. This Print is an Example of an O/W
Separator and is not Designed for
Specific Performance Ratings.
Openings can be Modified for
Specific Project Requirements.

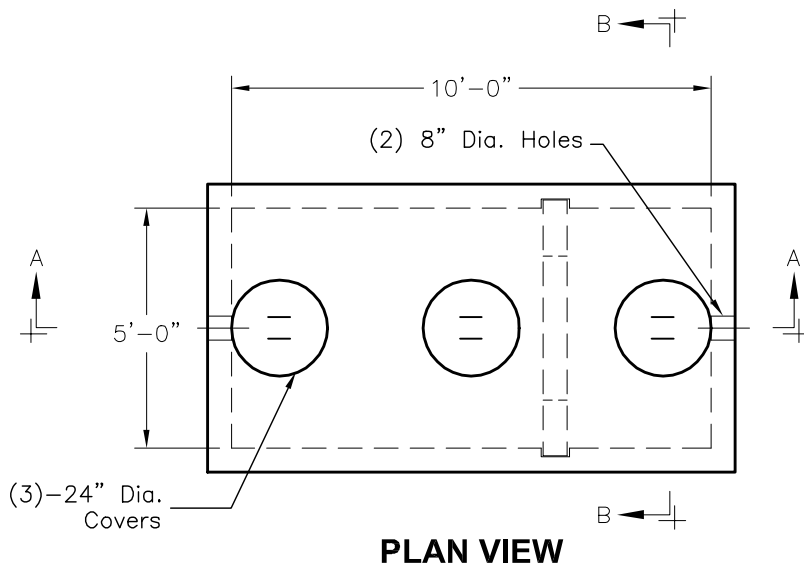

PLAN VIEW

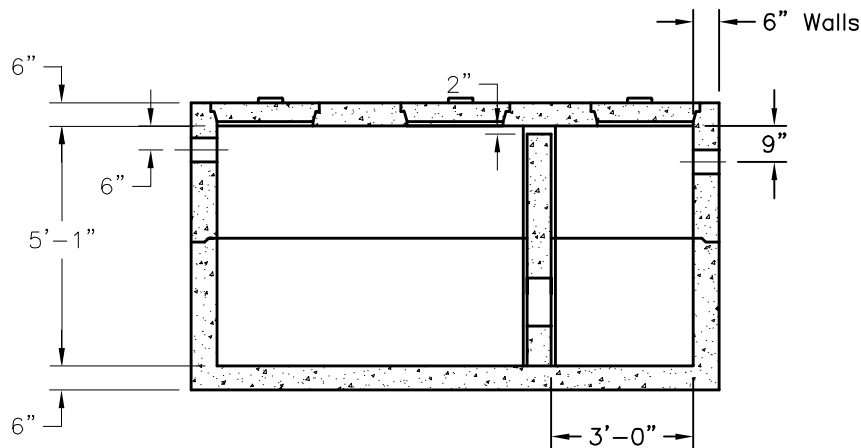

SECTION A-A

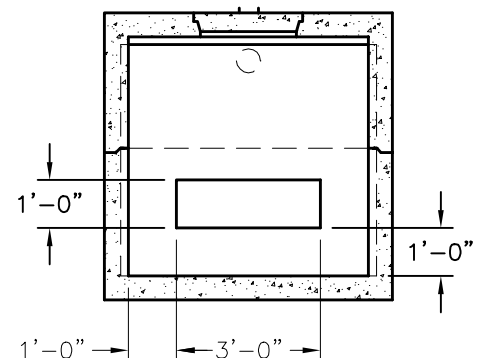

SECTION B-B



OW-1500

FILE NAME: 324ECOOW-1500_DET.DWG

ISSUE DATE: January, 2008

www.oldcastleprecast.com

**5'-0" x 10'-0" x 5'-1" I.D.
Oil/Water Separator
1,500 Gallon Capacity**

Copyright © 2008 **Oldcastle Precast**