

PLAN VIEW
SCALE: 3/8" = 1'-0"

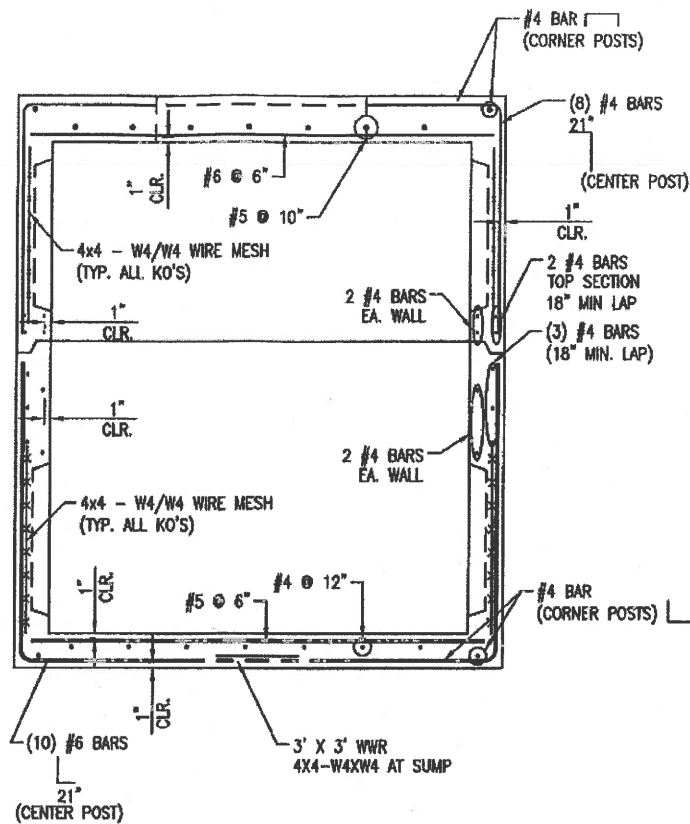

STEEL REINFORCEMENT
SCALE: 3/8" = 1'-0"

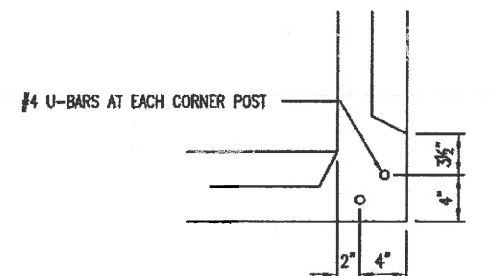

CORNER POST DETAIL
SCALE: 3/4" = 1'-0"

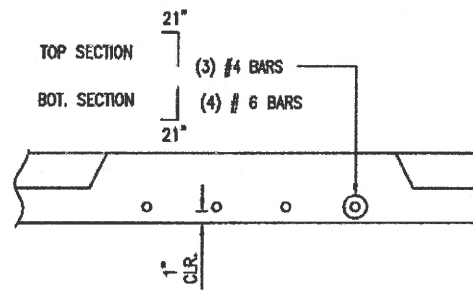

CENTER POST BEAM DETAIL
SCALE: N.T.S.

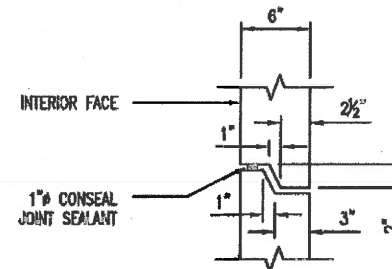

SHIPLAP JOINT DETAIL
N.T.S.

- DESIGN NOTES:**
1. TOP SECTION CONCRETE MIN. COMPRESSIVE STRENGTH 6000 PSI @ 28 DAYS & BOTTOM SECTION 6000 PSI.
 2. STEEL REINFORCEMENT REBAR - ASTM 615, GRADE 60.
 3. DESIGN LOADING PER BALTIMORE CITY HS-25 DESIGN CRITERIA.
 4. EARTH COVER = 1'-0" - 6'-0"
 5. GROUND WATER @ 3'-0" BELOW GRADE.

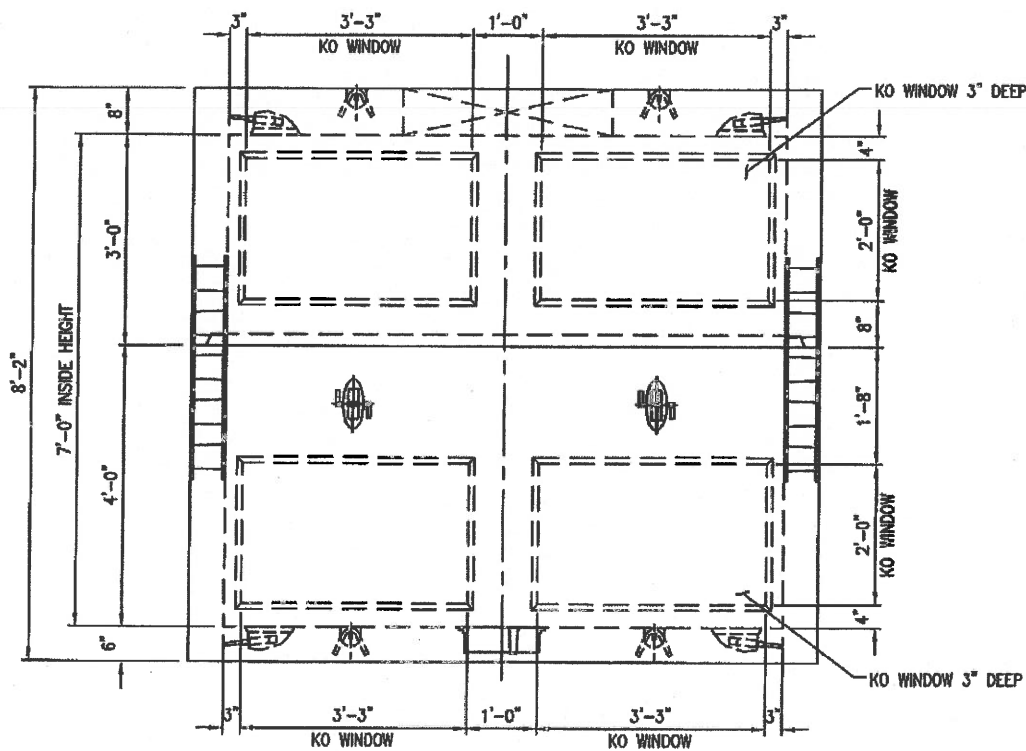

VIEW A
VIEW C IS TYPICAL
SCALE: 3/8" = 1'-0"

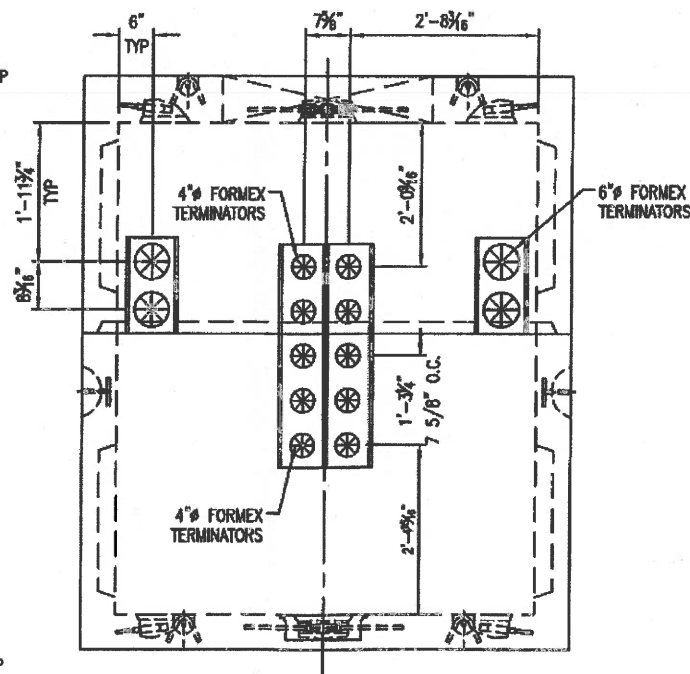

VIEW B
VIEW D IS TYPICAL
SCALE: 3/8" = 1'-0"

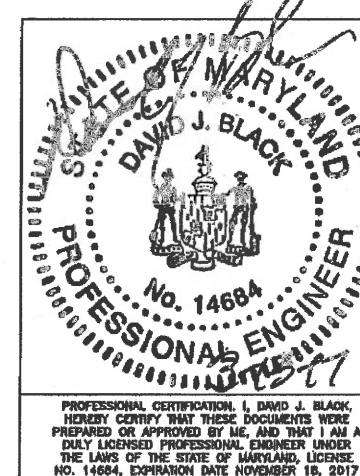

REVISION TABLE			
REV	REV DATE	BY	DESCRIPTION
1			
2			

Oldcastle Precast®
CHESAPEAKE REGION
5115 MASSAPONAX CHURCH ROAD, FREDERICKSBURG, VA 22407
OFFICE 540-894-4300, FAX 540-895-2589
1401 TRIMBLE ROAD, EDGEWOOD, MD 21040
OFFICE 410-288-1200, FAX 410-612-1214

THIS DOCUMENT IS THE PROPERTY OF OLDCASTLE PRECAST, INC. IT IS LOANED TO YOU FOR REFERENCE PURPOSES ONLY AND SHALL NOT BE USED IN ANY WAY IN VIOLATION OF THE INTERESTS OF OLDCASTLE PRECAST, INC. OR IN VIOLATION OF THE INTERESTS OF OLDCASTLE PRECAST, INC. ALL RIGHTS RESERVED.

6'x8'x4' BASE & 6'x8'x3' TOP HS-25
SUBMITTAL - LAYOUT

BG&E 0100119-0100285					
DATE	SALES	DRAWN	ENGINEER	CHECKED	SALES ORDER
03/10/17		CR	DJB	DJB	
DRAWING NUMBER				REVISION	SHEET
0100119-0100285				REV DATE	1 OF 1

PROFESSIONAL CERTIFICATION, I, DAVID J. BLACK, HEREBY CERTIFY THAT THESE DOCUMENTS WERE PREPARED OR APPROVED BY ME, AND THAT I AM A DULY LICENSED PROFESSIONAL ENGINEER UNDER THE LAWS OF THE STATE OF MARYLAND, LICENSE NO. 14684, EXPIRATION DATE NOVEMBER 18, 2017