

REV	DESCRIPTION	BY	DATE
A	NCS UPDATE	CP	6/27/17

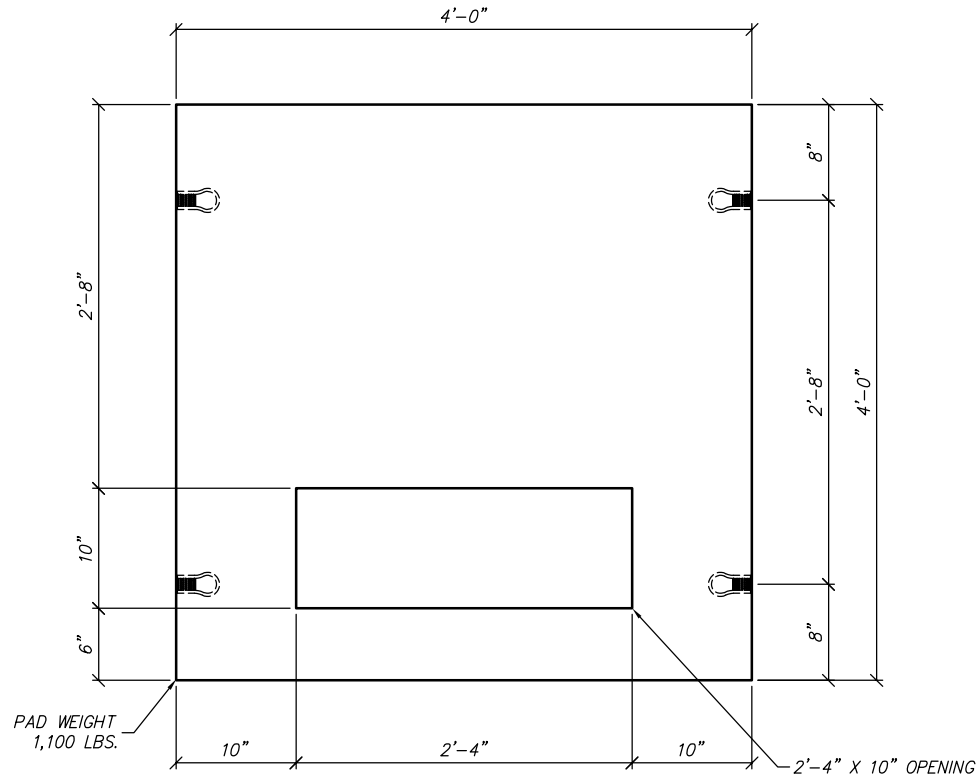

**PLAN VIEW**

SCALE: 3/4" = 1'-0"

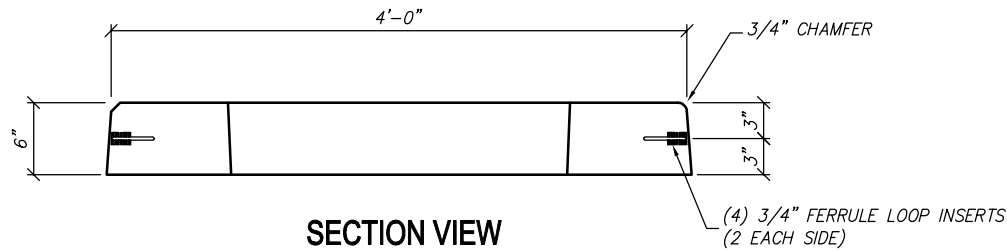

**SECTION VIEW**

SCALE: 3/4" = 1'-0"

**STRUCTURAL NOTES**

1. CONCRETE: 28 DAY COMPRESSIVE STRENGTH  $f_c = 5,000$  psi
2. REBAR: ASTM A-615 GRADE 60
3. MESH: ASTM A-1064 GRADE 65
4. DESIGN: ACI 318-14 BUILDING CODE
5. LOADS: 8,100 LB EQUIPMENT
6. SOIL COVER: NONE



THIS DOCUMENT IS THE PROPERTY OF OLDCASTLE PRECAST, INC. IT IS CONFIDENTIAL, SUBMITTED FOR REFERENCE PURPOSES ONLY, AND SHALL NOT BE USED IN ANY WAY INJURIOUS TO THE INTERESTS OF, OR WITHOUT THE WRITTEN PERMISSION OF OLDCASTLE PRECAST, INC. COPYRIGHT ©2017 OLDCASTLE PRECAST, INC. ALL RIGHTS RESERVED

**48" X 48" X 6" PRECAST CONCRETE PAD**

CUSTOMER  
**CITY OF MESA NO. U-2027**

DATE	SALES	DRAWN	ENGINEER	CHECKED	SALES ORDER
1/19/00		JM			—
DRAWING NUMBER				REVISION	SHEET
P5004-1				—	1 OF 1