

Washington GULD*

	CARTRIDGE SIZE	TREATMENT FLOW RATE GPM / CFS	TOTAL FLOW CAPACITY CFS
	12.00"	6.8 / 0.015	1.3
	18.00"	10.2 / 0.023	1.3
STACKED	12.00" + 12.00"	13.6 / 0.030	1.3
STACKED	18.00" + 12.00"	17 / 0.038	1.3

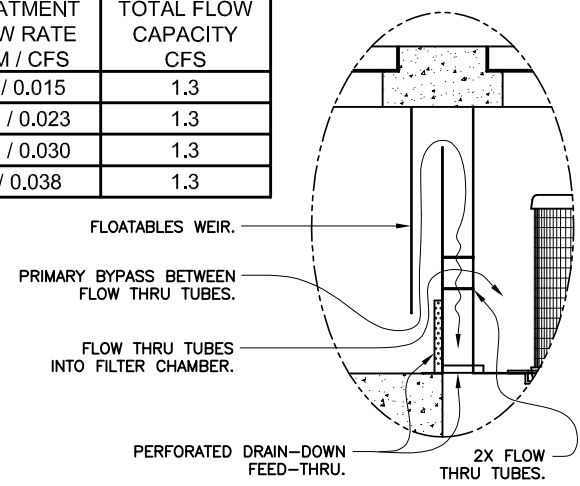
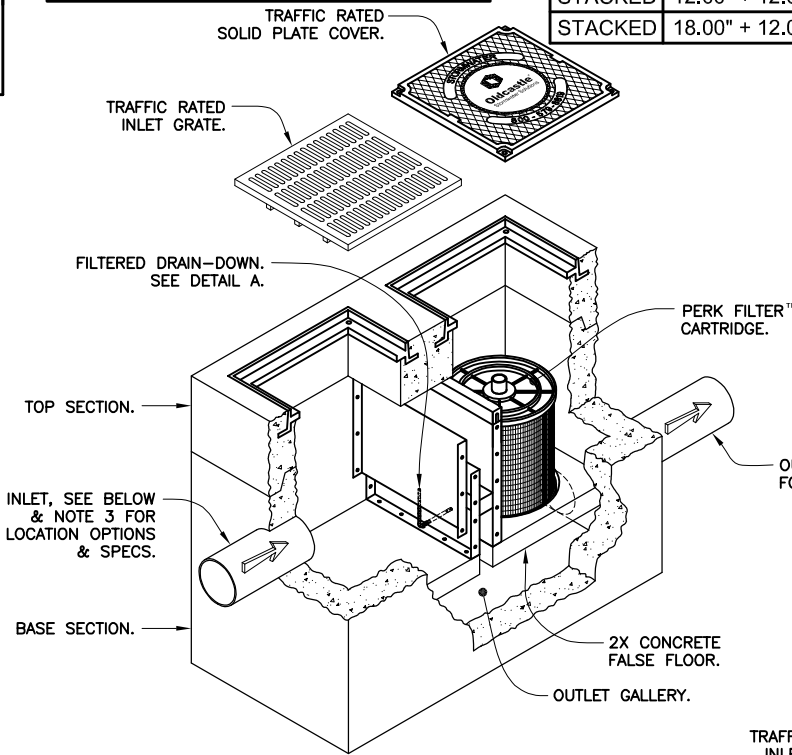

DETAIL A
INLET / BYPASS ASSEMBLY & DRAIN-DOWN SCALE: 2X

OUTLET. SEE BELOW & NOTE 3 FOR LOCATION OPTIONS & SPECS.

CARTRIDGE SIZE	MINIMUM DEPTHS (SEE NOTE 6)			
	Ø 6.0" OUTLET PIPE (IN INCHES)	Ø 8.0" OUTLET PIPE (IN INCHES)	Ø 10.0" OUTLET PIPE (IN INCHES)	Ø 12.0" OUTLET PIPE (IN INCHES)
12.00"	39	41	43	45
18.00"	46	48	50	52
STACKED 12.00" + 12.00"	56	58	60	62
STACKED 18.00" + 12.00"	63	65	67	69

Notes:

1. Precast concrete structure shall be manufactured in accordance with ASTM Designation C857 and C858.
2. Perk Filter™ Catch basin shall be supplied with traffic rated (H20) bicycle-proof grates and solid plate cover.
3. Inlet pipe(s) may enter device on three sides of the inlet chamber. Outlet pipe(s) may exit on all four sides. All pipe is Ø 12" maximum.
4. Inlet chamber shall be supplied with a drain-down device designed to remove standing water between storm events.
5. Perk Filter™ cartridge shall be maintained in accordance with manufacturer recommendations.
6. For depths less than the specified minimum contact Oldcastle® Stormwater Solutions for engineering assistance.

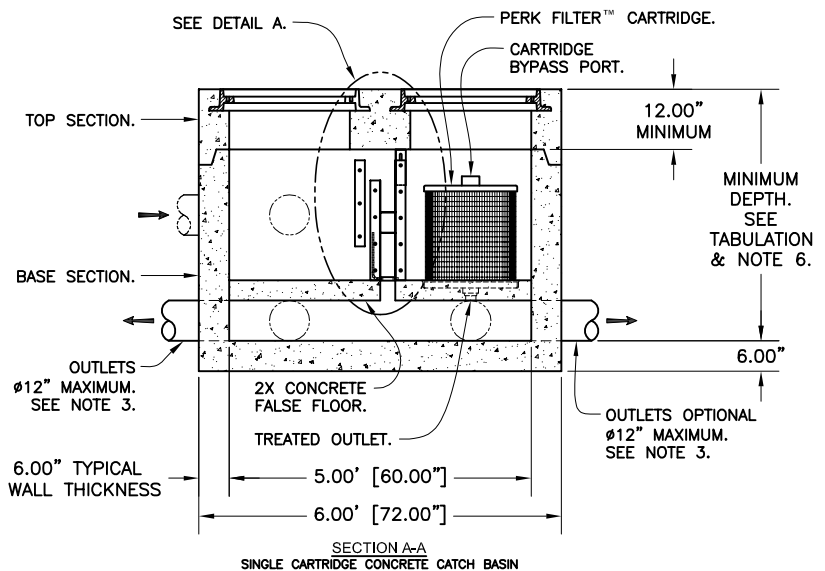
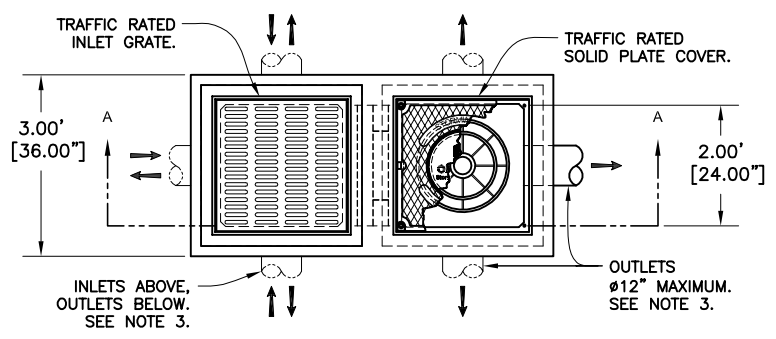

*** Treatment Flow Rates shown conform to Washington State GULD Specifications.**



Perk Filter™
Concrete Catch Basin
Washington State GULD
Single Cartridge



Oldcastle®
Stormwater Solutions

7921 Southpark Plaza, Suite 200 | Littleton, CO | 80120 | Ph: 800.579.8819 | oldcastlestormwater.com
THIS DOCUMENT IS THE PROPERTY OF OLDCASTLE PRECAST, INC. IT IS SUBMITTED FOR REFERENCE PURPOSES ONLY AND SHALL NOT BE USED IN ANY WAY INJURIOUS TO THE INTERESTS OF SAID COMPANY. COPYRIGHT © 2014 OLDCASTLE PRECAST, INC. ALL RIGHTS RESERVED.

DRAWING NO. PF-CCB-WA-0001	REV E	ECO ECO-0144	DATE ZHD 8/26/16	DATE JPR 3/2/11	SHEET 1 OF 1
-------------------------------	----------	-----------------	---------------------	--------------------	--------------