

4'-0" X 6'-6" X 6'-0"
 HEAVY FULL TRAFFIC H-20 SPLICE ENCLOSURE
 CODE NO: 04-1521
 APPROXIMATE WEIGHTS:
 WITHOUT COVER 13,910 LBS

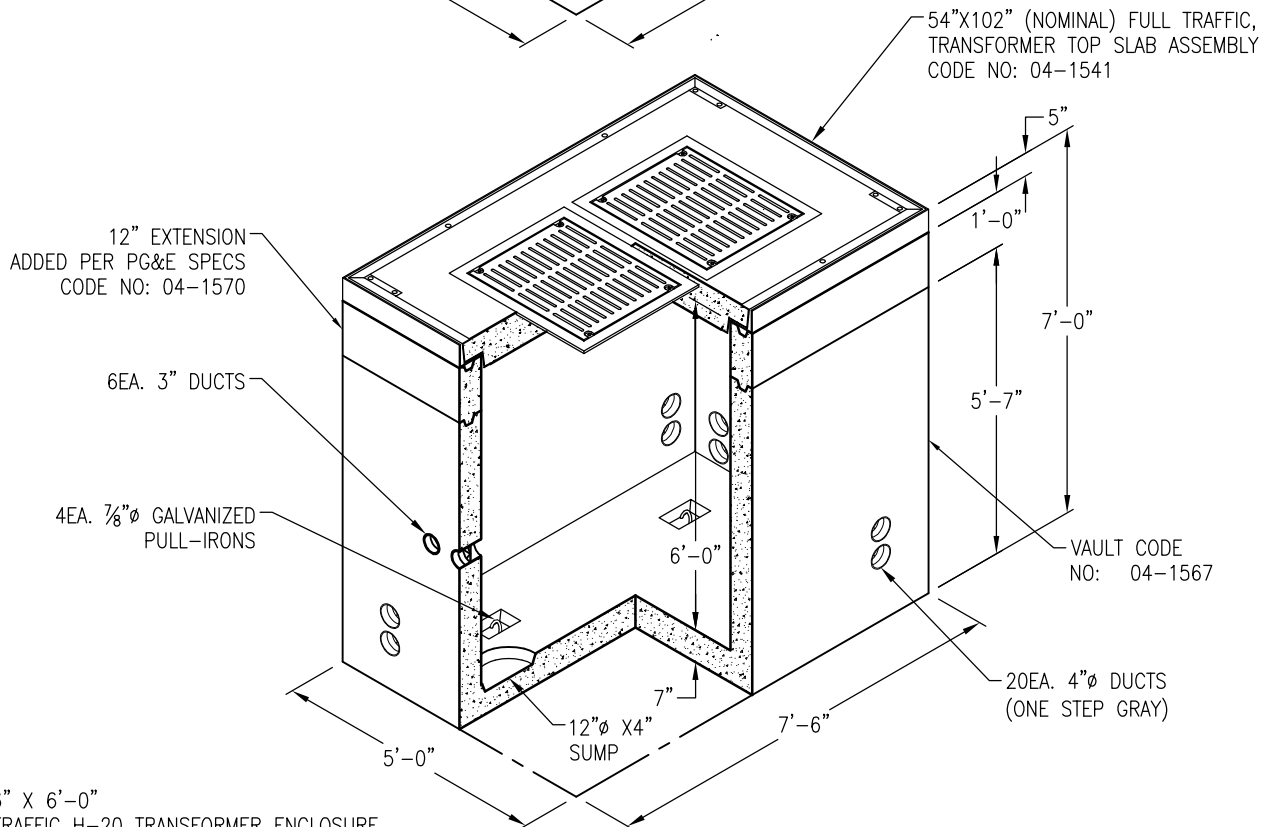
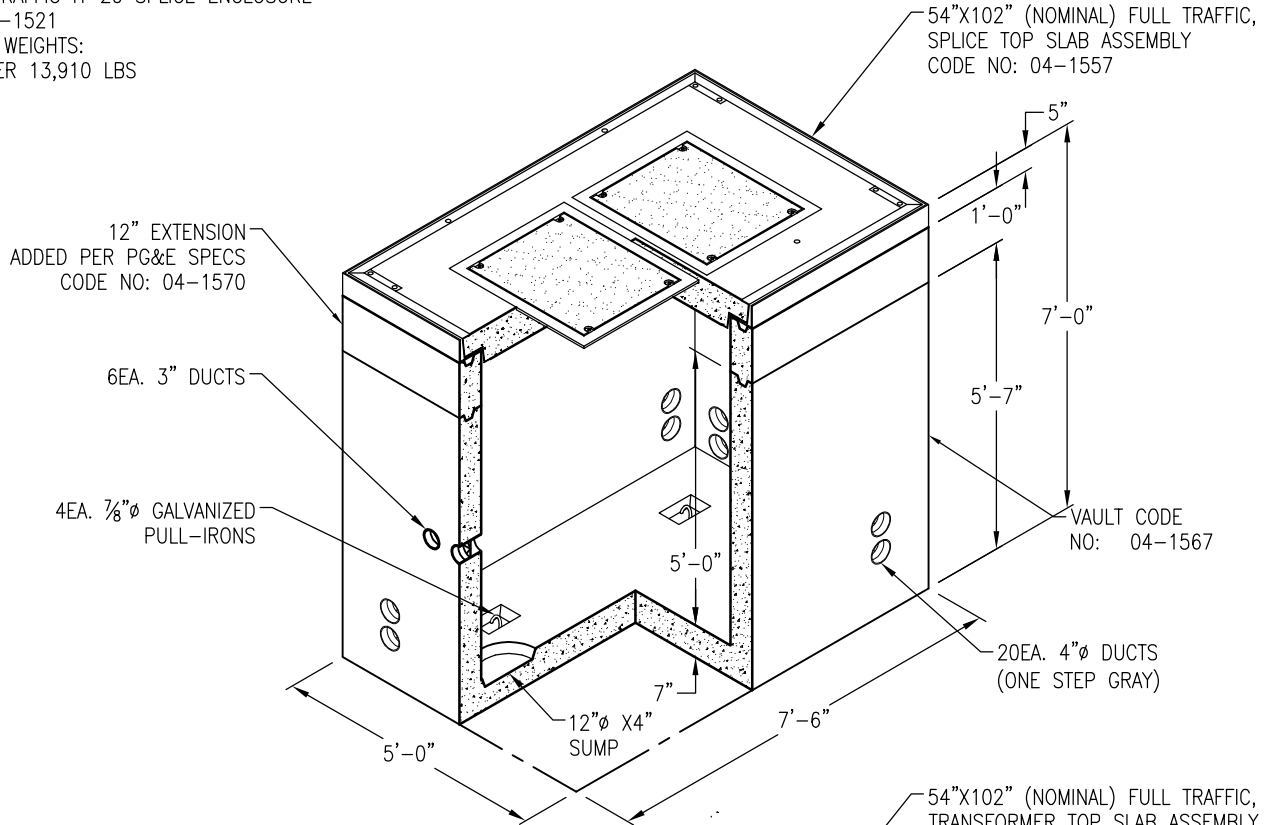

4'-0" X 6'-6" X 6'-0"
 HEAVY FULL TRAFFIC H-20 TRANSFORMER ENCLOSURE
 CODE NO: 04-1494
 APPROXIMATE WEIGHTS:
 WITHOUT COVER 13,910 LBS

DRAWING MAY NOT CONFORM TO THE
 MOST CURRENT SPECIFICATION

Oldcastle Precast[®]
 Northern California
 Madera ■ Morgan Hill ■ Pleasanton ■ Santa Rosa ■ Stockton ■ Tulare
 Phone: 925-750-6650 Fax: 925-750-6660

PG&E 4666HFT
 FILE NAME: PGE-13.DWG
 REVISED: MARCH 2016
www.oldcastleprecast.com

**4'-0" X 6'-6" X 6'-0" (I.D.)
 4666 TRAFFIC ENCLOSURE
 PG&E**
 Copyright © 2016 Oldcastle Precast, Inc.