

4'-6" X 8'-6" X 6'-0"
 FULL TRAFFIC H-20 NTE<25 MPH SPLICE ENCLOSURE
 CODE NO: 04-1666
 APPROXIMATE WEIGHTS:
 WITHOUT COVER 17,630 LBS

54"X102" (NOMINAL) H-20 TRAFFIC,
 ADJUSTABLE, SLIP RESISTANT, GALVANIZED,
 SPLICE COVER ASSEMBLY
 CODE NO: 04-1054

3EA. 3"Ø DUCTS

16EA. 6"Ø DUCTS
 7EA. 5"Ø DUCTS

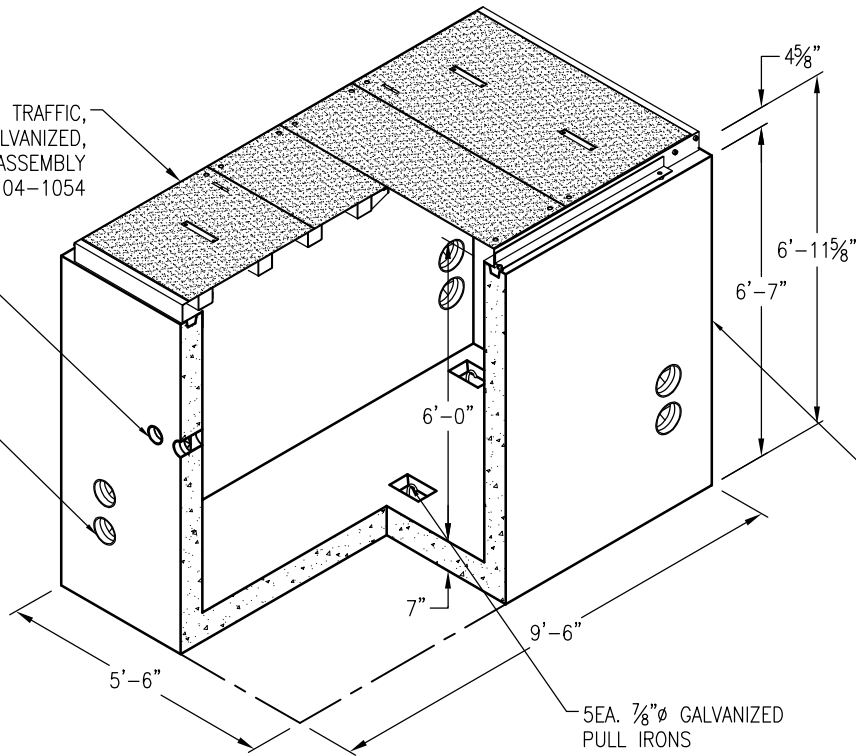

54"X102" (NOMINAL) H-20 TRAFFIC,
 ADJUSTABLE, SLIP RESISTANT, GALVANIZED,
 TRANSFORMER COVER ASSEMBLY
 CODE NO: 04-1055

3EA. 3"Ø DUCTS

16EA. 6"Ø DUCTS
 7EA. 5"Ø DUCTS

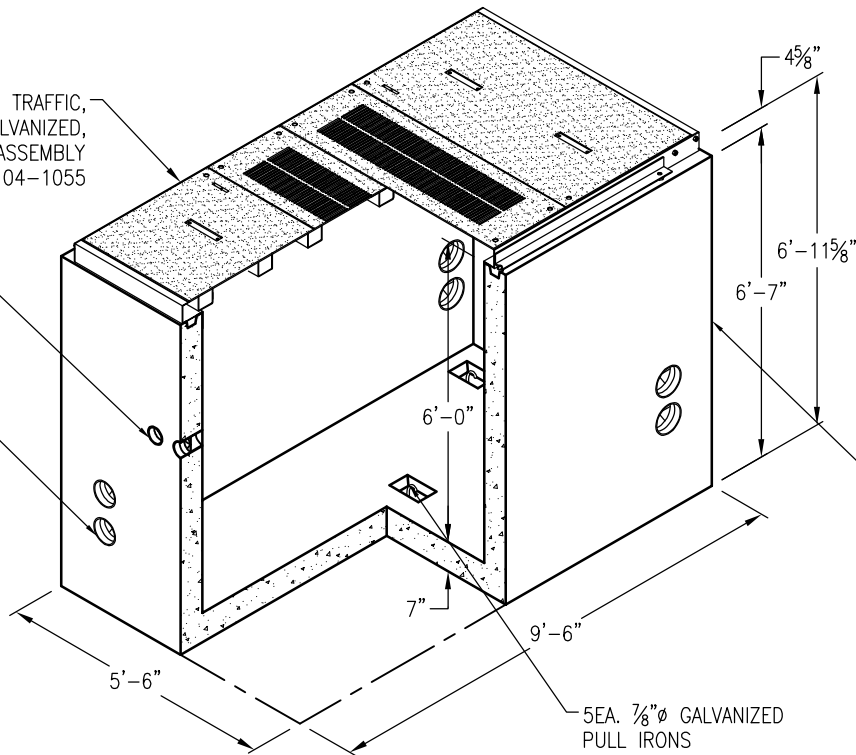

4'-6" X 8'-6" X 6'-0"
 FULL TRAFFIC H-20 NTE<25 MPH TRANSFORMER ENCLOSURE
 CODE NO: 04-1649
 APPROXIMATE WEIGHTS:
 WITHOUT COVER 17,630 LBS

DRAWING MAY NOT CONFORM TO THE
 MOST CURRENT SPECIFICATION

Oldcastle Precast[®]

Northern California
 Madera ■ Morgan Hill ■ Pleasanton ■ Santa Rosa ■ Stockton ■ Tulare
 Phone: 925-750-6650 Fax: 925-750-6660

PG&E 4686T
FILE NAME: PGE-15.DWG
REVISED: MARCH 2016
www.oldcastleprecast.com

4'-6" X 8'-6" X 6'-0" (I.D.)
 4686 TRAFFIC ENCLOSURE
 PG&E