

4'-6" X 8'-6" X 7'-6"  
 INCIDENTAL H-10 NTE<25 MPH TRANSFORMER ENCLOSURE  
 CODE NO: 04-0325  
 APPROXIMATE WEIGHTS:  
 WITHOUT COVER 20,863 LBS

54"x102" (NOMINAL) INCIDENTAL TRAFFIC,  
 QUICK RELEASE, SLIP RESISTANT, ALUMINUM,  
 EPOXY COATED GRATES  
 TRANSFORMER COVER ASSEMBLY  
 CODE NO: 03-1830

3EA. 3"Ø DUCTS

16EA. 6"Ø DUCTS  
 7EA. 5"Ø DUCTS

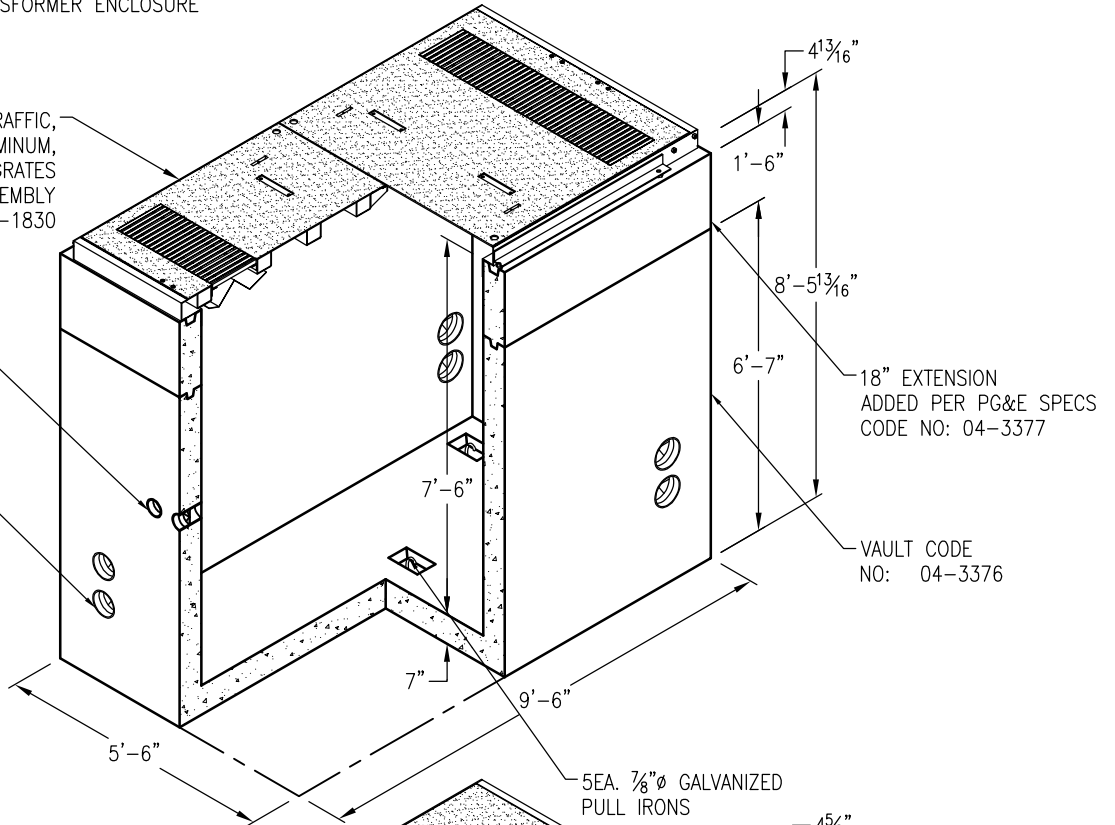

54"x102" (NOMINAL) H-20 TRAFFIC,  
 ADJUSTABLE, SLIP RESISTANT, GALVANIZED,  
 TRANSFORMER COVER ASSEMBLY  
 CODE NO: 04-1055

3EA. 3"Ø DUCTS

16EA. 6"Ø DUCTS  
 7EA. 5"Ø DUCTS

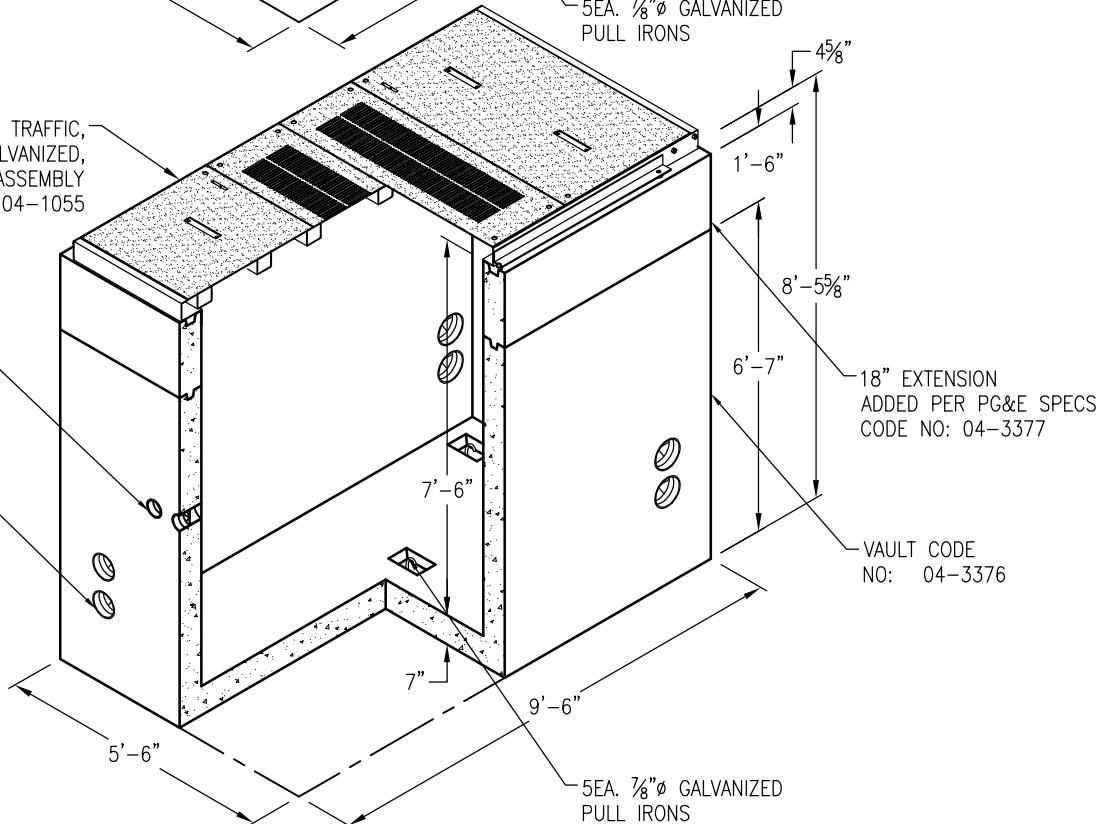

4'-6" X 8'-6" X 7'-6"  
 FULL TRAFFIC H-20 NTE<25 MPH TRANSFORMER ENCLOSURE  
 CODE NO: 04-1662  
 APPROXIMATE WEIGHTS:  
 WITHOUT COVER 19,786 LBS

DRAWING MAY NOT CONFORM TO THE  
 MOST CURRENT SPECIFICATION

**Oldcastle Precast**<sup>®</sup>  
 Northern California  
 Madera ■ Morgan Hill ■ Pleasanton ■ Santa Rosa ■ Stockton ■ Tulare  
 Phone: 925-750-6650 Fax: 925-750-6660

|  |
|--|
| PG&E 4686T   |
| FILE NAME: PGE-16.DWG  |
| REVISED: MARCH 2016  |
| <a href="http://www.oldcastleprecast.com">www.oldcastleprecast.com</a> |

4'-6" X 8'-6" X 7'-6" (I.D.)  
 4686 TRAFFIC ENCLOSURE  
 PG&E  
 Copyright © 2016 Oldcastle Precast, Inc.