

4'-6" X 8'-6" X 7'-0"
 HEAVY FULL TRAFFIC H-20 SPLICE ENCLOSURE
 CODE NO: 04-1441
 APPROXIMATE WEIGHTS:
 WITHOUT COVER 19,786 LBS

54"x102" (NOMINAL) FULL TRAFFIC,
 SPLICE TOP SLAB ASSEMBLY
 CODE NO: 04-1443

3EA. 3"Ø DUCTS

16EA. 6"Ø DUCTS
 7EA. 5"Ø DUCTS

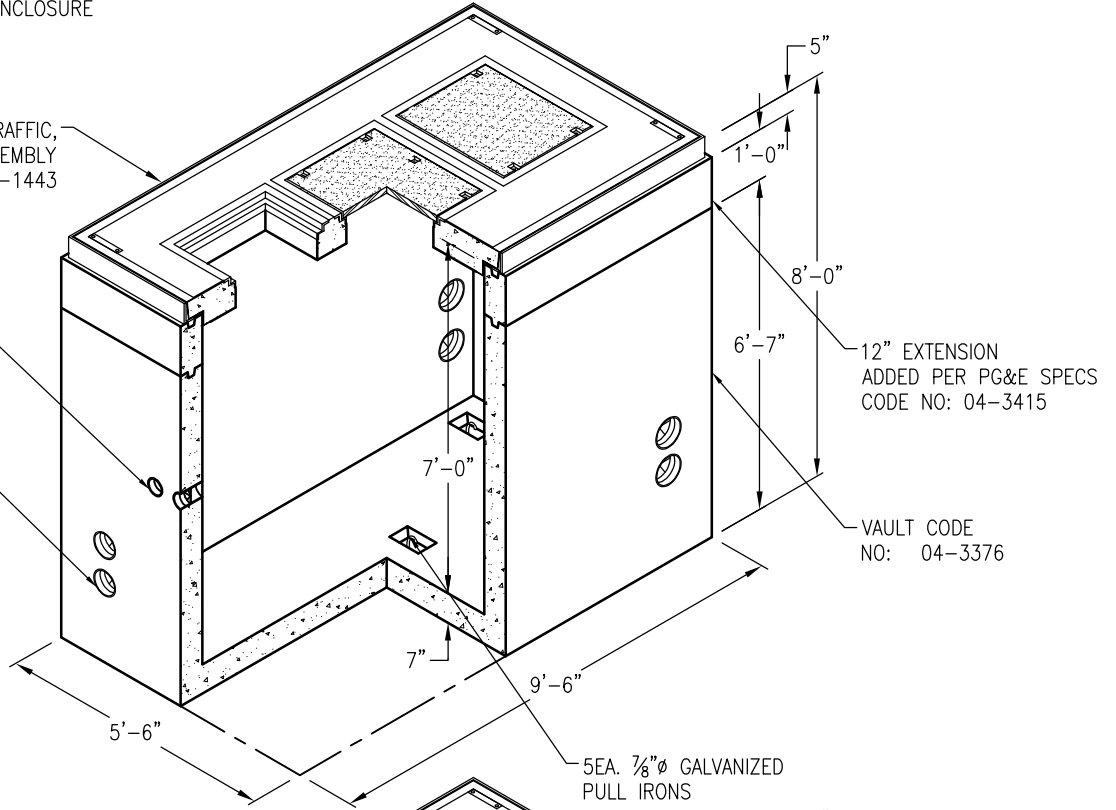

54"x102" (NOMINAL) FULL TRAFFIC,
 TRANSFORMER TOP SLAB ASSEMBLY
 CODE NO: 04-1442

3EA. 3"Ø DUCTS

16EA. 6"Ø DUCTS
 7EA. 5"Ø DUCTS

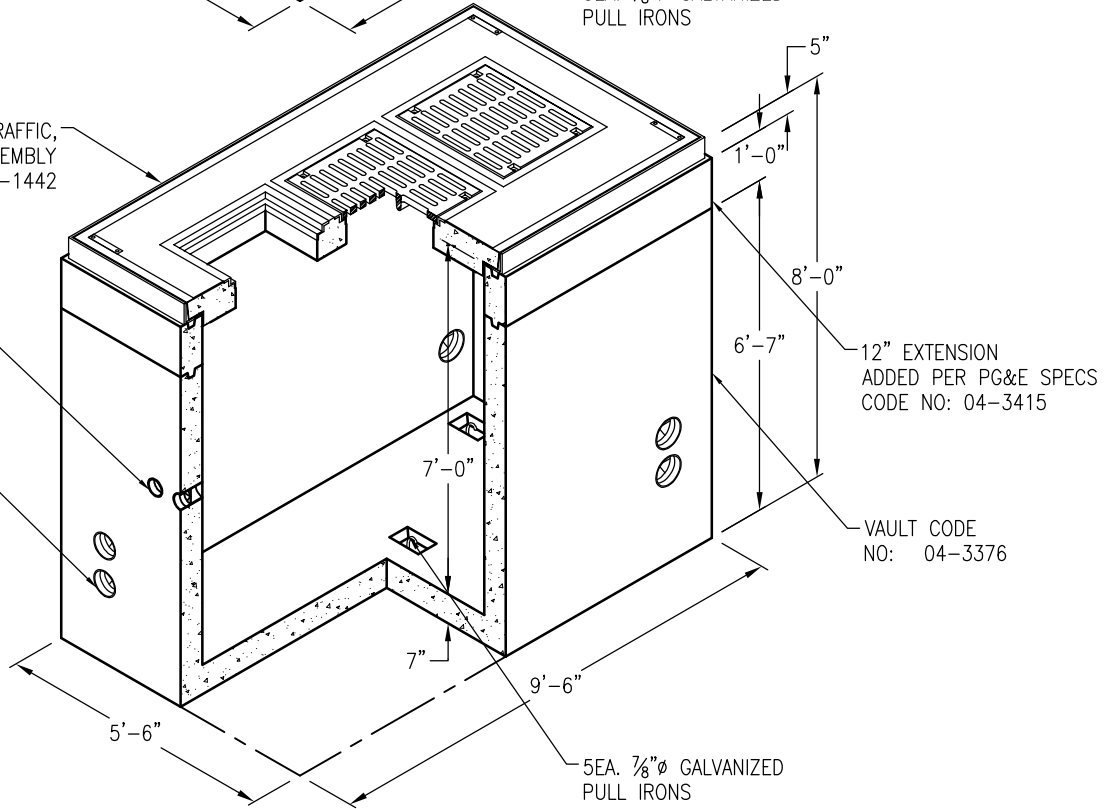

4'-6" X 8'-6" X 7'-0"
 HEAVY FULL TRAFFIC H-20 TRANSFORMER ENCLOSURE
 CODE NO: 04-1439
 APPROXIMATE WEIGHTS:
 WITHOUT COVER 19,786 LBS

DRAWING MAY NOT CONFORM TO THE
 MOST CURRENT SPECIFICATION

Oldcastle Precast[®]
 Northern California
 Madera ■ Morgan Hill ■ Pleasanton ■ Santa Rosa ■ Stockton ■ Tulare
 Phone: 925-750-6650 Fax: 925-750-6660

PG&E 4686HFT
FILE NAME: PGE-17.DWG
REVISED: MARCH 2016
www.oldcastleprecast.com

4'-6" X 8'-6" X 7'-0" (I.D.)
4686 TRAFFIC ENCLOSURE
PG&E