

SINGLE PHASE CABINET TRANSFORMER PAD
 CODE NO.: 04-3542
 APPROXIMATE WEIGHT: 700 LBS

PGE-24

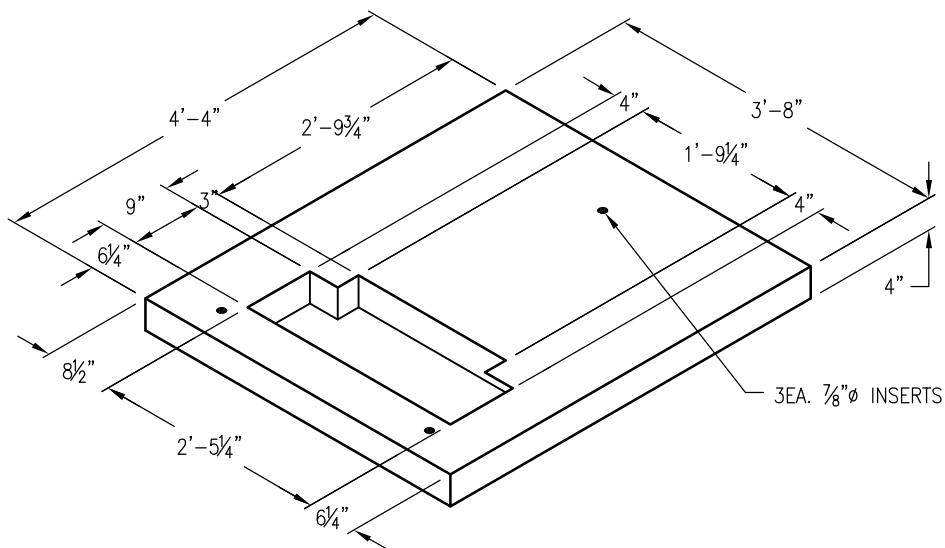

SINGLE PHASE CABINET TRANSFORMER PAD
 CODE NO.: 04-3543
 APPROXIMATE WEIGHT: 802 LBS

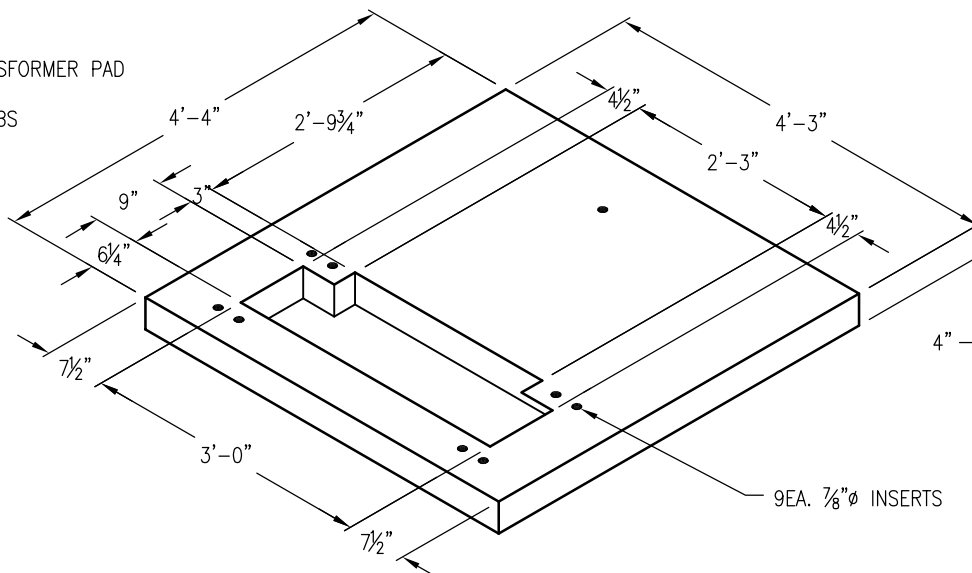

DRAWING MAY NOT CONFORM TO THE
 MOST CURRENT SPECIFICATION