

3'-0" X 5'-0" X 2'-6"  
 FULL TRAFFIC H-20 NTE<25 MPH SPLICE ENCLOSURE  
 CODE NO: 04-2019  
 APPROXIMATE WEIGHTS:  
 WITHOUT COVER 4,830 LBS

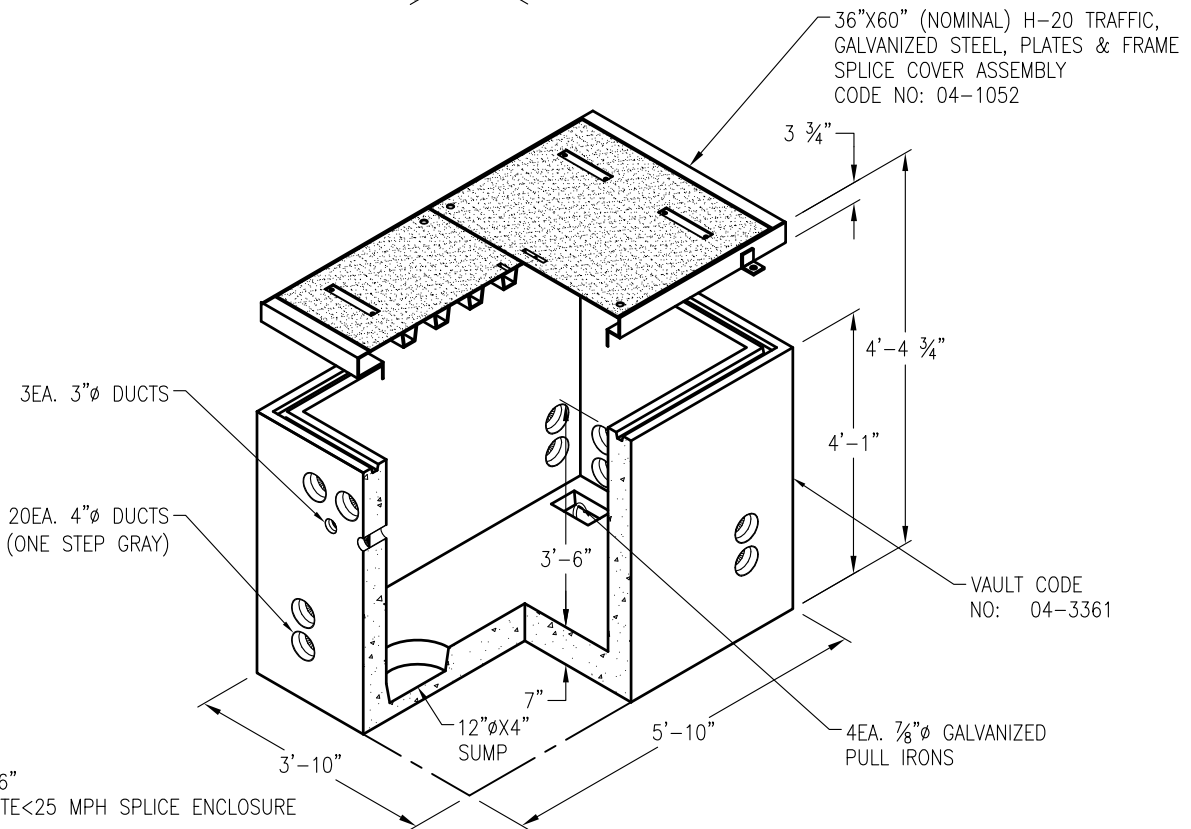
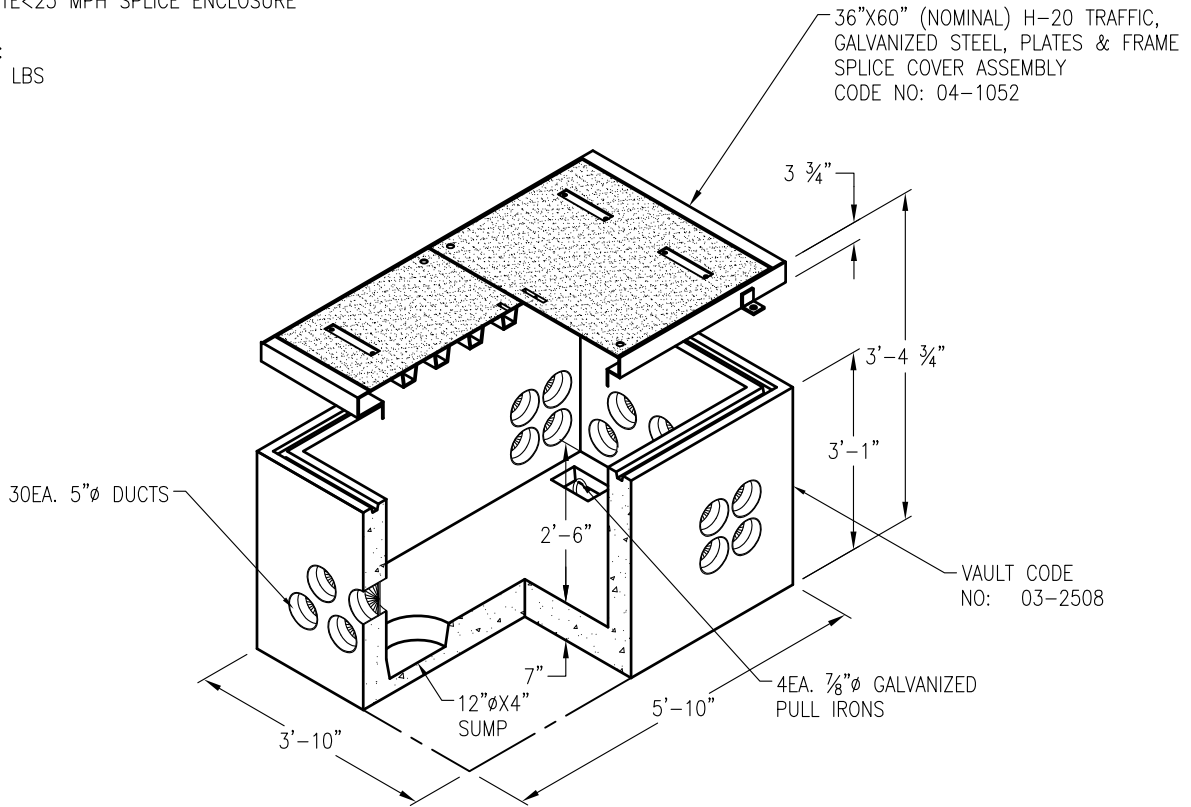

3'-0" X 5'-0" X 3'-6"  
 FULL TRAFFIC H-20 NTE<25 MPH SPLICE ENCLOSURE  
 CODE NO: 04-1668  
 APPROXIMATE WEIGHTS:  
 WITHOUT COVER 5,960 LBS

DRAWING MAY NOT CONFORM TO THE MOST CURRENT SPECIFICATION

**Oldcastle Precast**<sup>®</sup>  
 Northern California  
 Madera ■ Morgan Hill ■ Pleasanton ■ Santa Rosa ■ Stockton ■ Tulare  
 Phone: 925-750-6650 Fax: 925-750-6660

PG&E 352636T
FILE NAME: PGE-5.DWG
REVISED: MARCH 2016
www.oldcastleprecast.com

3'-0" X 5'-0" X VARIES (I.D.)  
 35 TRAFFIC ENCLOSURE  
 PG&E