

3'-0" X 5'-0" X 2'-6"  
 HEAVY FULL TRAFFIC H-20 SPLICE ENCLOSURE  
 CODE NO: 03-2507  
 APPROXIMATE WEIGHTS:  
 WITHOUT COVER 6,000 LBS

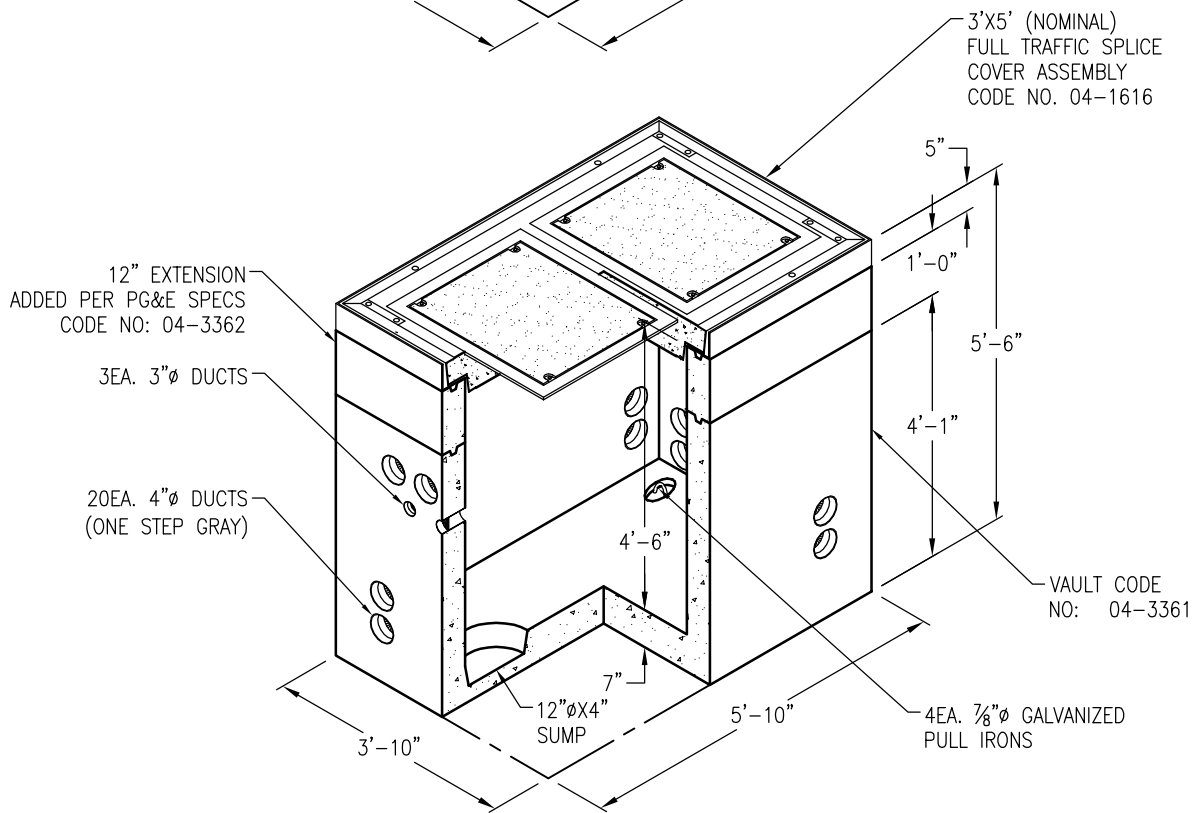

3'-0" X 5'-0" X 3'-6"  
 HEAVY FULL TRAFFIC H-20 SPLICE ENCLOSURE  
 CODE NO: 04-1612  
 APPROXIMATE WEIGHTS:  
 WITHOUT COVER 7,085 LBS

DRAWING MAY NOT CONFORM TO THE  
 MOST CURRENT SPECIFICATION

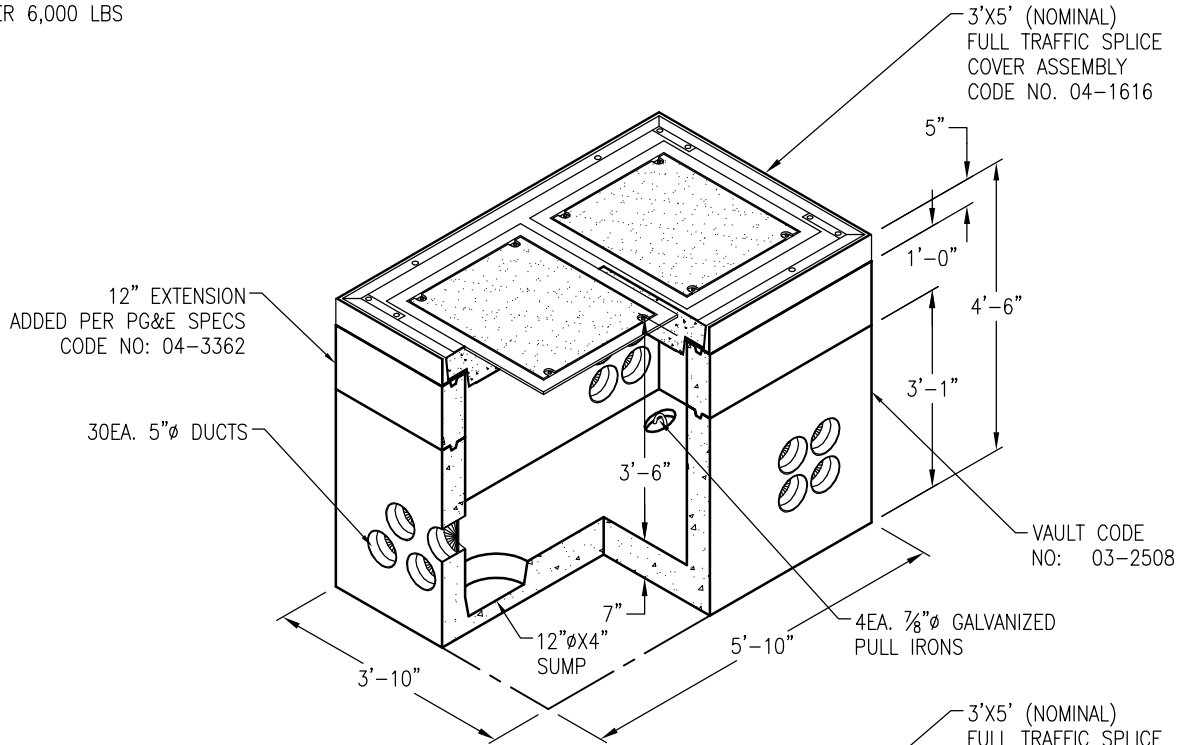

**Oldcastle Precast**<sup>®</sup>

Northern California  
 Madera ■ Morgan Hill ■ Pleasanton ■ Santa Rosa ■ Stockton ■ Tulare  
 Phone: 925-750-6650 Fax: 925-750-6660

PG&E 352636HFT
FILE NAME: PGE-6.DWG
REVISED: MARCH 2016
<a href="http://www.oldcastleprecast.com">www.oldcastleprecast.com</a>

3'-0" X 5'-0" X VARIES (I.D.)  
 35 TRAFFIC ENCLOSURE  
 PG&E