

3'-0" X 5'-0" X 4'-6"
 HEAVY FULL TRAFFIC H-20 SPLICE ENCLOSURE
 CODE NO: 04-0327
 APPROXIMATE WEIGHTS:
 WITHOUT COVER 8,215 LBS

PGE-9

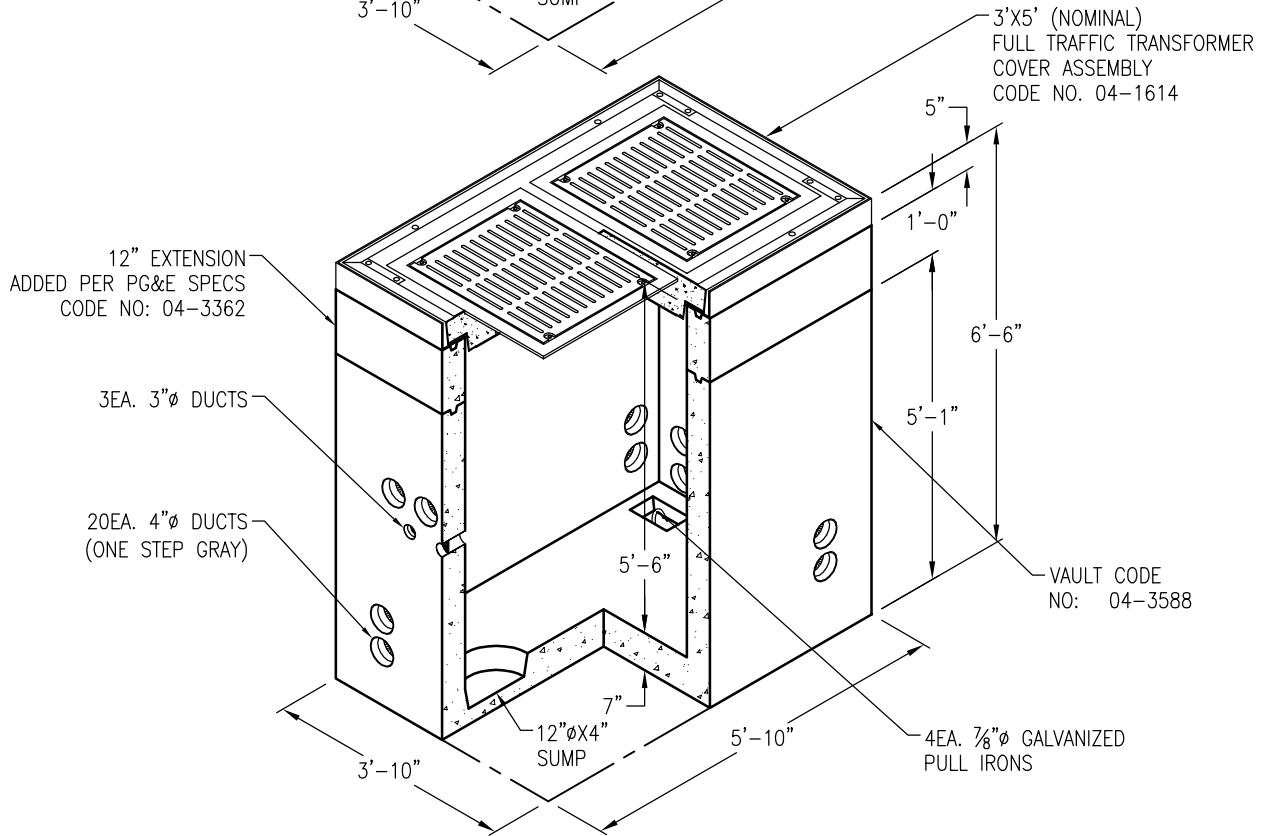
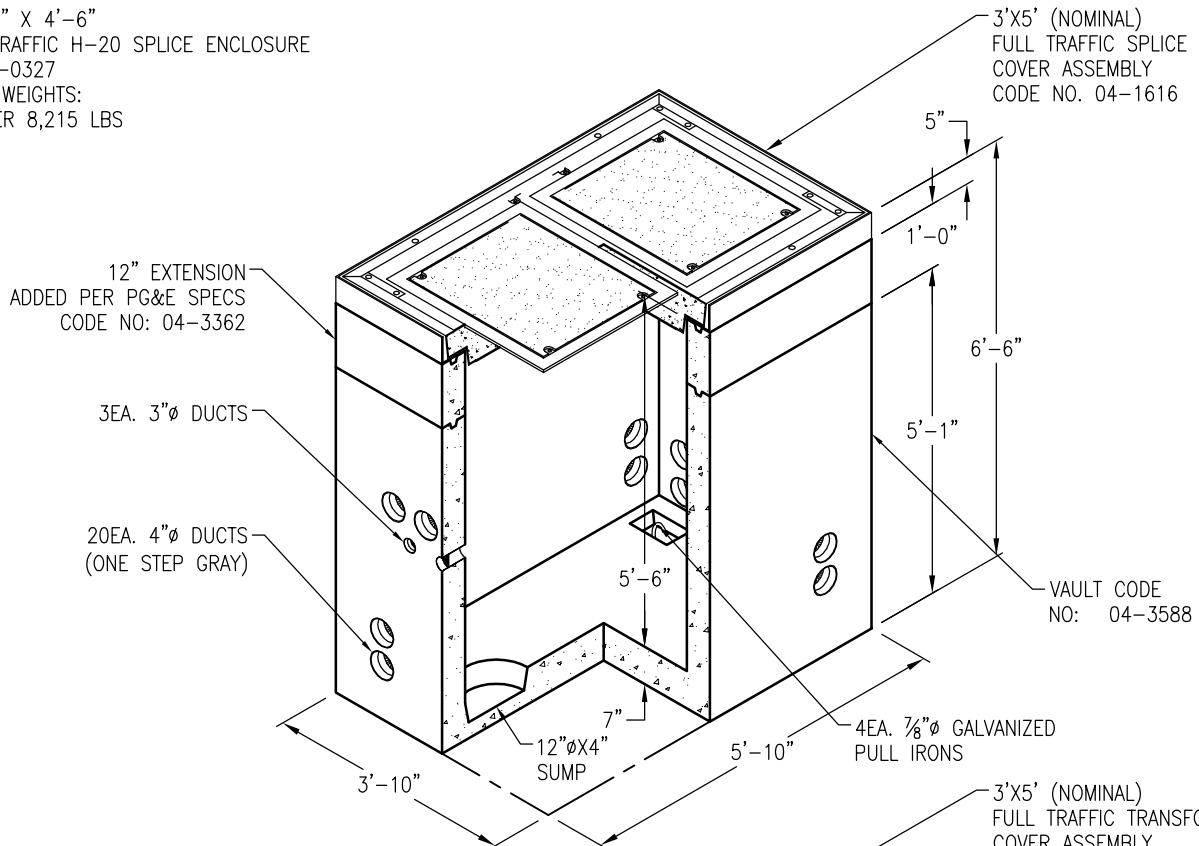

3'-0" X 5'-0" X 4'-6"
 HEAVY FULL TRAFFIC H-20 TRANSFORMER ENCLOSURE
 CODE NO: 04-1611
 APPROXIMATE WEIGHTS:
 WITHOUT COVER 8,215 LBS

DRAWING MAY NOT CONFORM TO THE
 MOST CURRENT SPECIFICATION

Oldcastle Precast[®]

Northern California
 Madera ■ Morgan Hill ■ Pleasanton ■ Santa Rosa ■ Stockton ■ Tulare
 Phone: 925-750-6650 Fax: 925-750-6660

PG&E 3546HFT
FILE NAME: PGE-9.DWG
REVISED: MARCH 2016
www.oldcastleprecast.com

3'-0" X 5'-0" X 4'-6" (I.D.)
 3546 TRAFFIC ENCLOSURE
 PG&E