

**NOTES:**

1. VAULTS ARE DESIGNED TO MEET ASTM C858 WITH AASHTO HS-20 LOADING.
2. OPENINGS MAY BE SIZED AND LOCATED AS REQUIRED.
3. OPTIONAL ACCESSORIES MAY BE CAST IN AS REQUIRED.
4. FOR OPTIONAL ACCESSORIES CHECK ACCESSORIES / HARDWARE SECTION.
5. IT IS RECOMMENDED THAT BITUMINOUS MASTIC BE USED AT ALL JOINTS.



2240 S. Yellowstone Hwy, Idaho Falls, Idaho 83402  
 Phone: 208-522-6150 Fax: 208-522-9701

**VAULTS**

FILE NAME: 230TBUV06

ISSUE DATE: 1/2011

[www.oldcastleprecast.com](http://www.oldcastleprecast.com)

**Utility Vault**  
**4' X 6' X 6'-2 1/2"**  
**ISO View**

Copyright © 2011

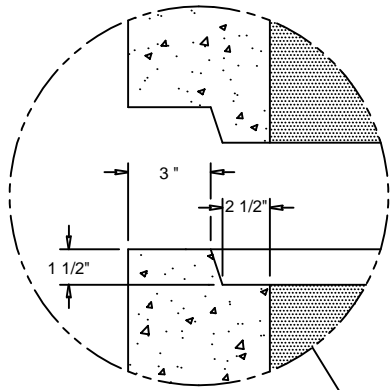

**JOINT DETAIL**  
SHOWN OPEN  
FOR CLARITY

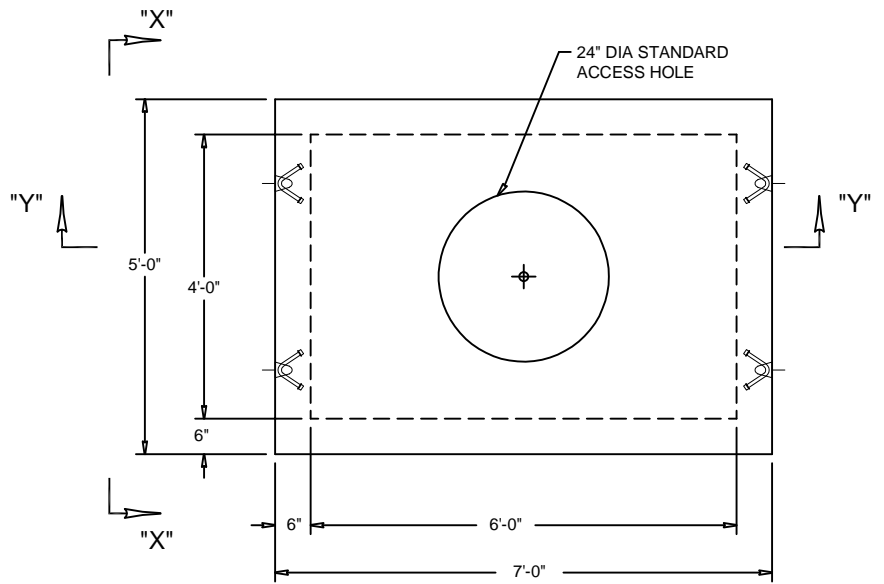

**PLAN VIEW**

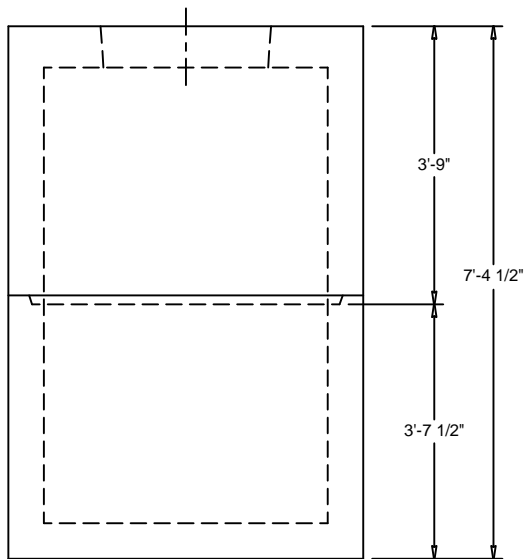

**VIEW "X"-"X"**

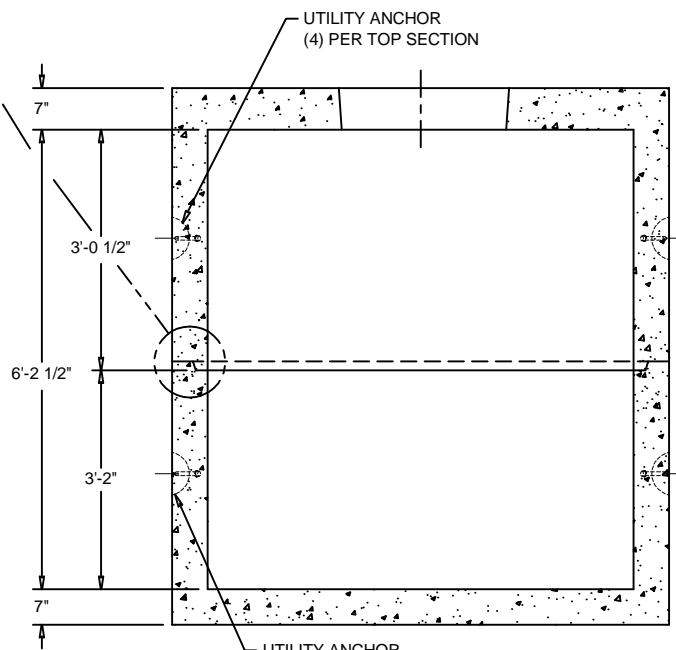

**SECTION "Y"-"Y"**



2240 S. Yellowstone Hwy, Idaho Falls, Idaho 83402  
Phone: 208-522-6150 Fax: 208-522-9701

# VAULTS

FILE NAME: 230TBUV06

ISSUE DATE: 1/2011

[www.oldcastleprecast.com](http://www.oldcastleprecast.com)

**Utility Vault**  
**4' X 6' X 6'-2 1/2"**

Copyright © 2011