

NOTES:

1. VAULTS CAN BE DESIGNED TO MEET ASTM C858 AND AASHTO LOADINGS.
2. OPENINGS MAY BE SIZED AND LOCATED AS SPECIFIED WITHIN STRUCTURAL LIMITATIONS.
3. OPTIONAL ACCESSORIES MAY BE INSTALLED AS SPECIFIED.
4. FOR OPTIONAL ACCESSORIES, SEE ACCESSORIES / HARDWARE SECTION.
5. IT IS RECOMMENDED THAT BITUMINOUS MASTIC BE USED AT ALL JOINTS.



2240 S. Yellowstone Hwy, Idaho Falls, Idaho 83402
 Phone: 208-522-6150 Fax: 208-522-9701

VAULTS

FILE NAME: 230TBUV011

ISSUE DATE: 1/2011

www.oldcastleprecast.com

Utility Vault

6' X 12' X 8'

ISO View

Copyright © 2011

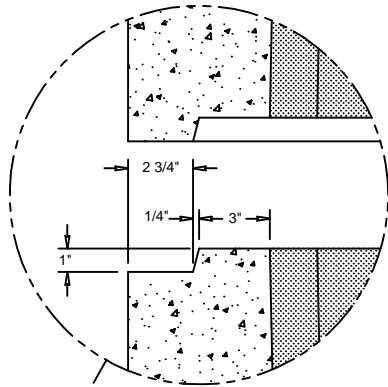

JOINT DETAIL
SHOWN OPEN
FOR CLARITY

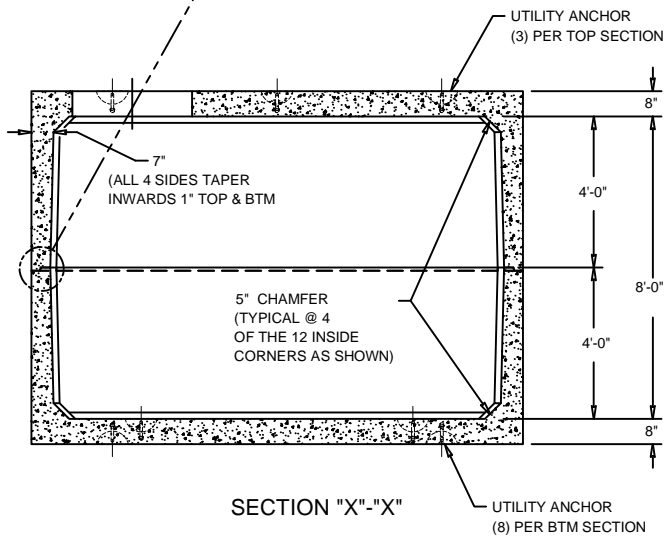

SECTION "X"-"X"

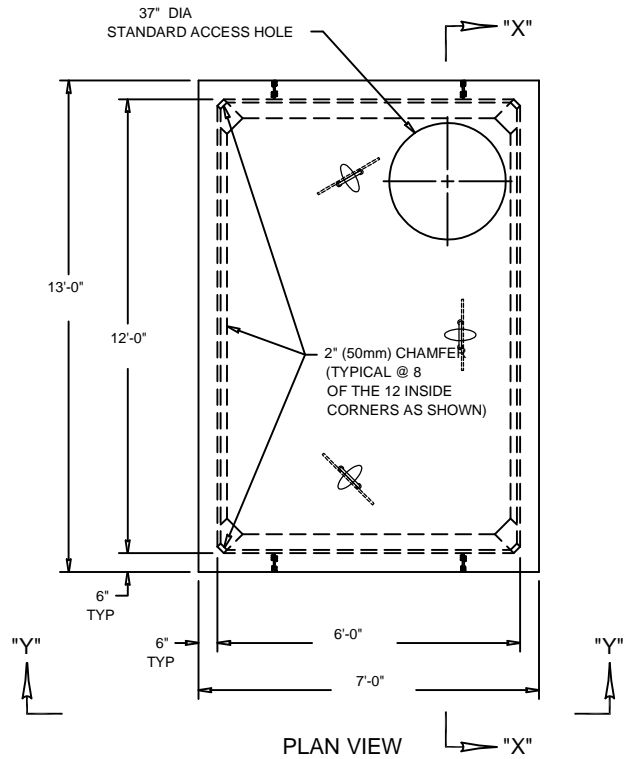

PLAN VIEW

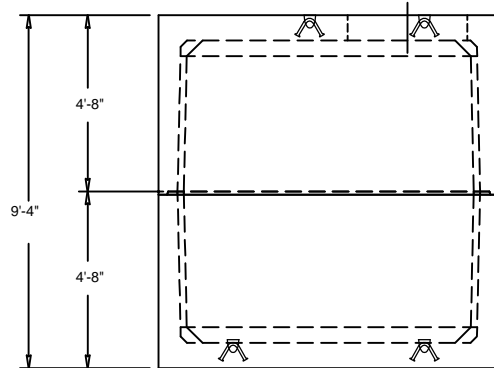

VIEW "Y"-"Y"



2240 S. Yellowstone Hwy, Idaho Falls, Idaho 83402
Phone: 208-522-6150 Fax: 208-522-9701

VAULTS

FILE NAME: 230TBUV011

ISSUE DATE: 1/2011

www.oldcastleprecast.com

Utility Vault
6' X 12' X 8'

Copyright © 2011