

**NOTES:**

1. VAULTS CAN BE DESIGNED TO MEET ASTM C858 AND AASHTO LOADINGS.
2. OPENINGS MAY BE SIZED AND LOCATED AS SPECIFIED WITHIN STRUCTURAL LIMITATIONS.
3. OPTIONAL ACCESSORIES MAY BE INSTALLED AS SPECIFIED.
4. FOR OPTIONAL ACCESSORIES, SEE ACCESSORIES / HARDWARE SECTION.
5. IT IS RECOMMENDED THAT BITUMINOUS MASTIC BE USED AT ALL JOINTS.
6. METRIC EQUIVALENTS (SHOWN IN PARENTHESIS) ARE ROUNDED TO NEAREST 5mm OR 5Kg.



2240 S. Yellowstone Hwy, Idaho Falls, Idaho 83402  
Phone: 208-522-6150 Fax: 208-522-9701

# VAULTS

FILE NAME: 230TBUV021

ISSUE DATE: 1/2011

[www.oldcastleprecast.com](http://www.oldcastleprecast.com)

**Utility Vault**  
**8' X 20' X 8'**  
**ISO View**

Copyright © 2011

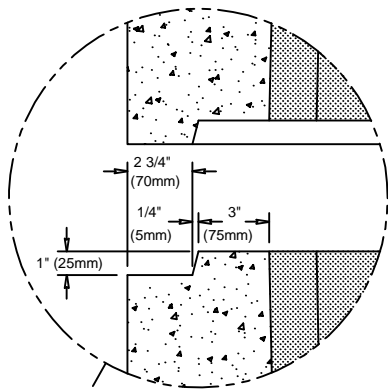

**JOINT DETAIL**  
SHOWN OPEN  
FOR CLARITY

MB 8 TON X 6 3/4" LONG SL ANCHOR  
(4) PER TOP SECTION

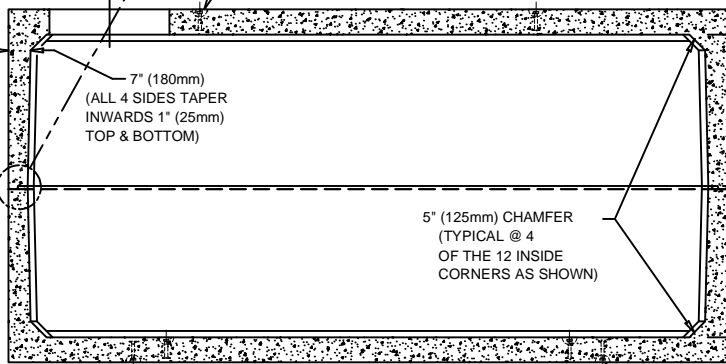

**SECTION "X"-"X"**

MB 8 TON X 6 3/4" LONG SL ANCHOR  
(8) PER BTM SECTION

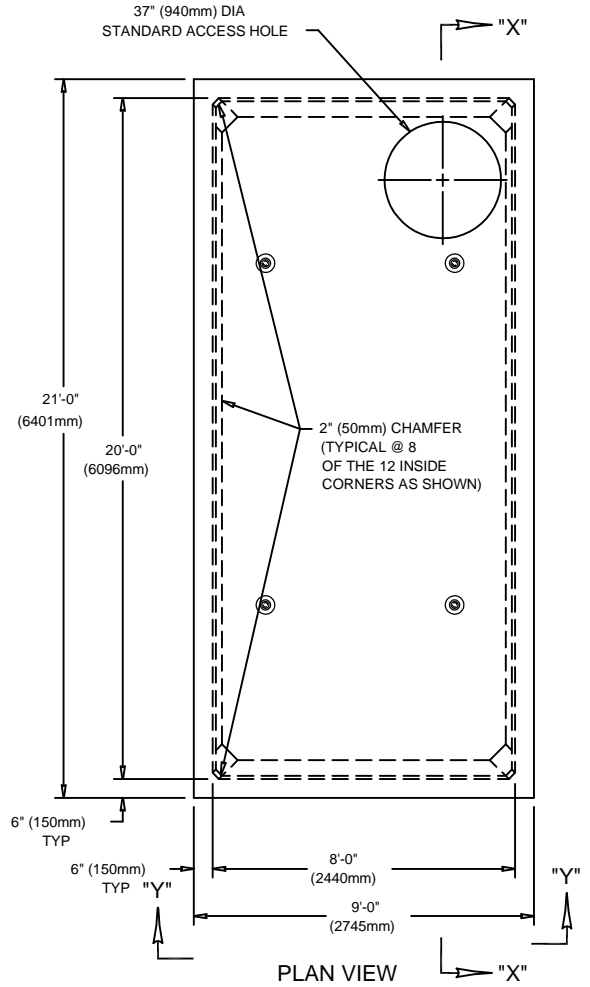

**PLAN VIEW**

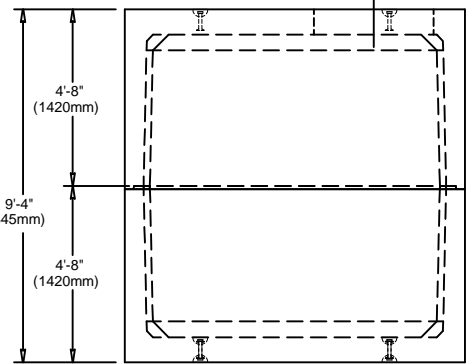

**VIEW "Y"-"Y"**



2240 S. Yellowstone Hwy, Idaho Falls, Idaho 83402  
Phone: 208-522-6150 Fax: 208-522-9701

# VAULTS

FILE NAME: 230TBUV021

ISSUE DATE: 1/2011

[www.oldcastleprecast.com](http://www.oldcastleprecast.com)

**Utility Vault**  
**8' X 20' X 8'**

Copyright © 2011