

48"X48" (NOMINAL) ADJUSTABLE, ALUMINUM W/SS PENTAHEAD BOLTS & SPRING NUTS FRAME AND COVER ASSEMBLY. AVAILABLE IN PEDESTRIAN OR INCIDENTAL TRAFFIC RATING SLIP RESISTANT COVER

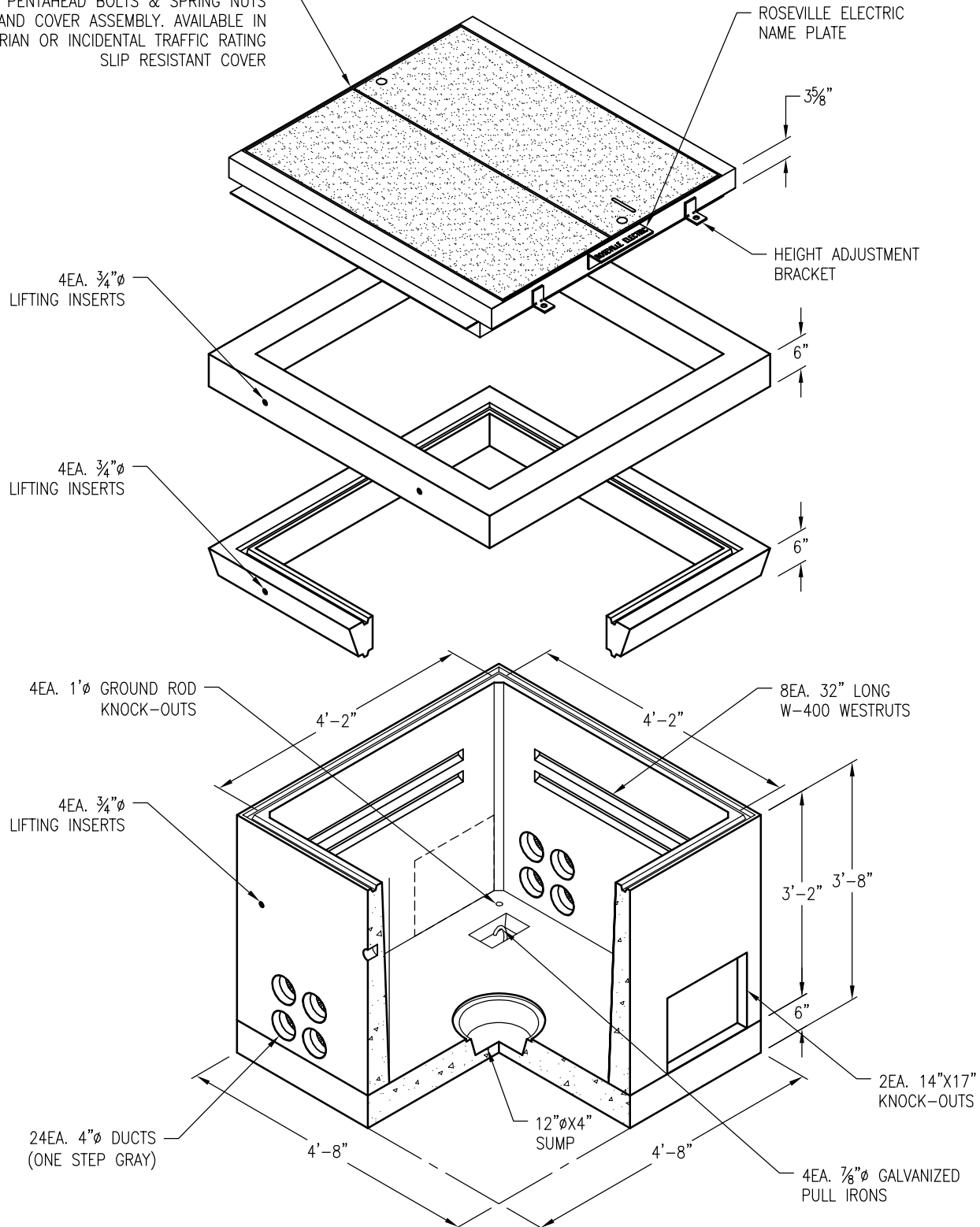

COVER RING WEIGHT: 640 LBS.
 RISER WEIGHT: 460 LBS.
 VAULT WEIGHT: 2,160 LBS.
 FLOOR SLAB WEIGHT: 1,650 LBS

DRAWING MAY NOT CONFORM TO THE MOST CURRENT SPECIFICATION



Oldcastle Precast

Northern California

Madera ■ Morgan Hill ■ Pleasanton ■ Santa Rosa ■ Stockton ■ Tulare
 Phone: 925-750-6650 Fax: 925-750-6660

RVE-504-INT

FILE NAME: RVE-3.DWG

REVISED: MARCH 2016

www.oldcastleprecast.com

4'-2" X 4'-2" X 3'-2" (I.D.)
 UTILITY VAULT INTERCEPT
 ROSEVILLE ELECTRIC

Copyright © 2016 Oldcastle Precast, Inc.