

NOTE: Penetrations and Tank Dimensions Shown Are For Illustration Purposes Only. Actual Penetration Sizes & Locations and Tank Dimensions & Capacity Will Vary According To Customer's needs.

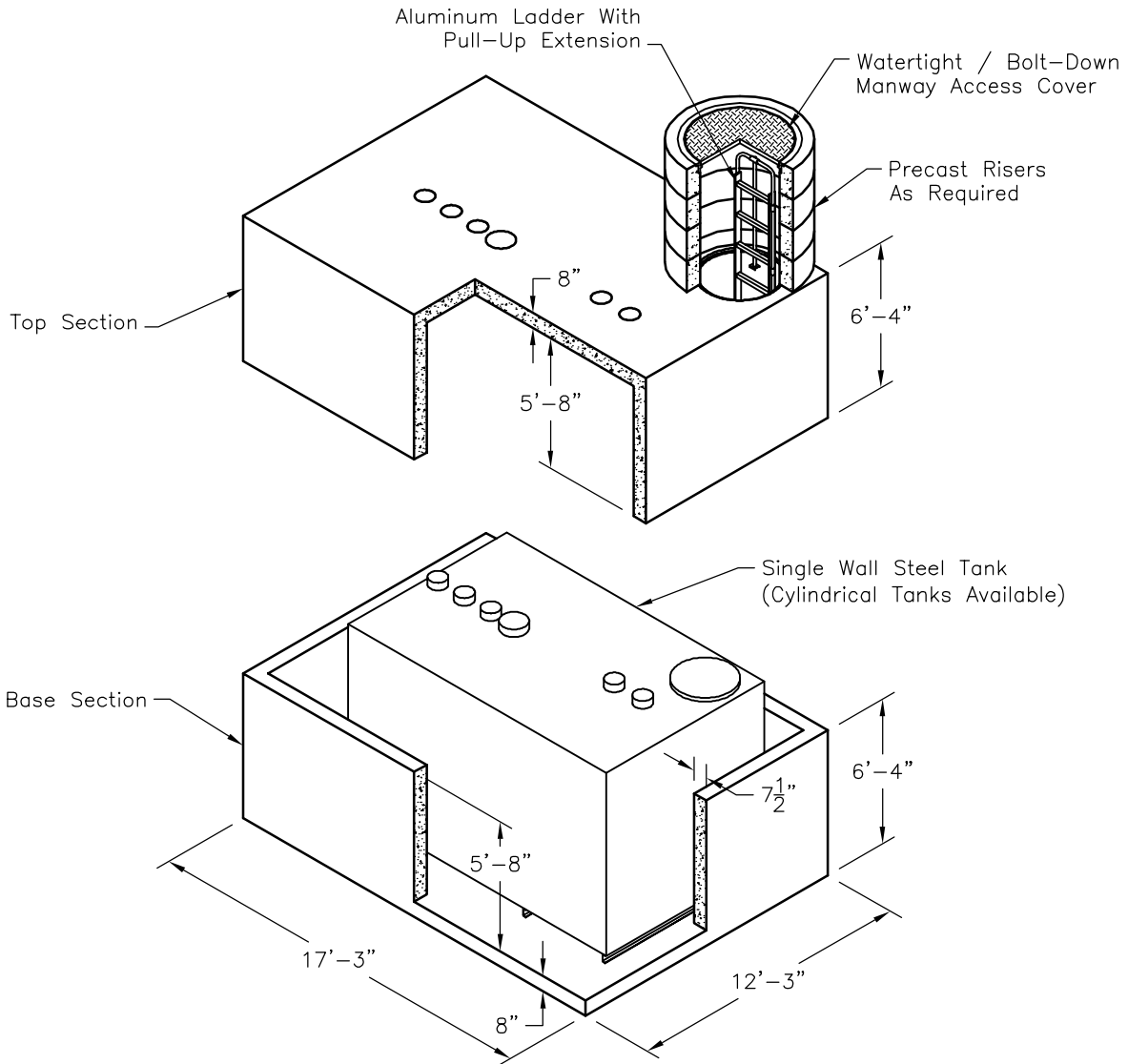

Approximate Weights  
Top - 51200 Lbs  
Base - 50100 Lbs

SCALE: 1/8" = 1'-0"

Overall Outside Dimensions  
12'-3"W x 17'-3"L x 12'-8"H  
Overall Inside Dimensions  
11'-0"W x 16'-0"L x 11'-4"H  
Minimum Excavation Is To Be  
12" Larger Than Product On  
All Sides