

26" x 26" Knockout
1 Ea. End Wall
2 Total

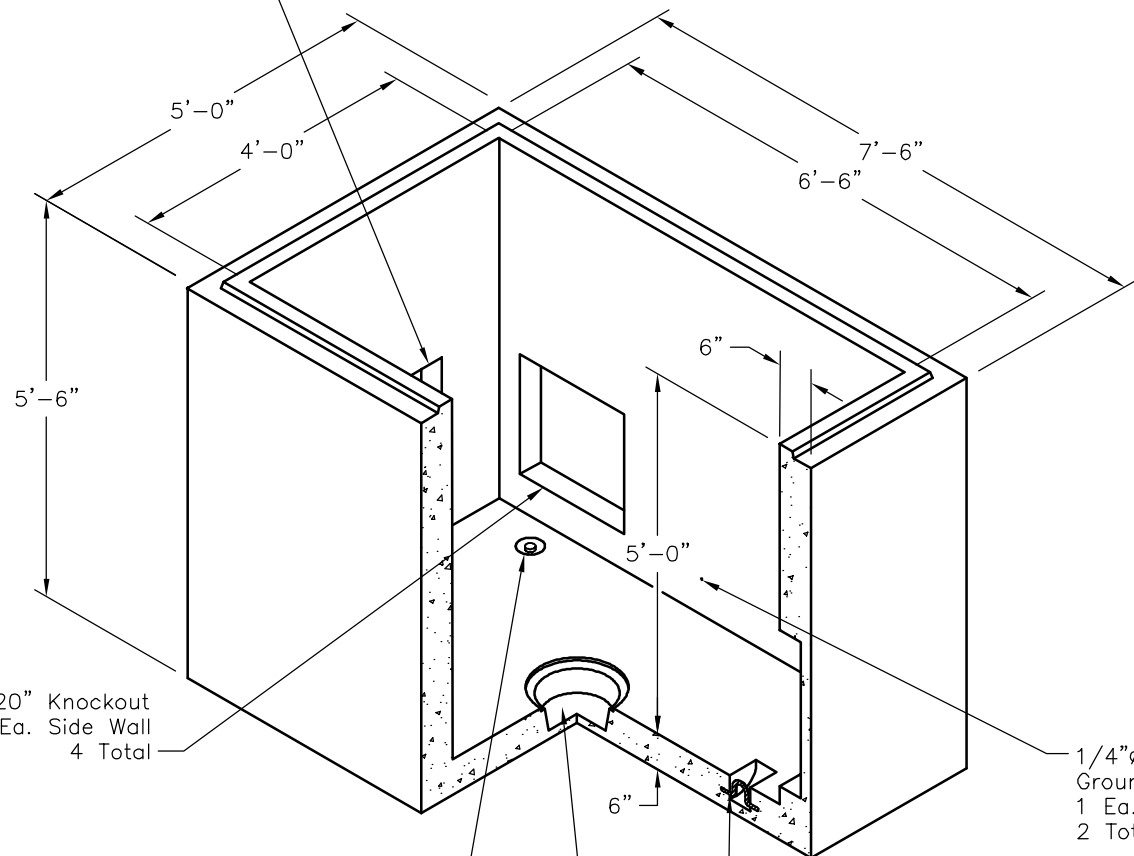

4 Ton Swiftlifts
4 For Stripping
4 For Placing
8 Total

7/8" ϕ Pull Irons
2 Total

12" ϕ Sump

Overall Outside Dimensions
5'-0"W x 7'-6"L x 6'-6"H
Overall Inside Dimensions
4'-0"W x 6'-6"L x 6'-0"H
Minimum Excavation Is To Be
12" Larger Than Product On
All Sides

Approximate Weights
Top - 1700 Lbs
Base - 10400 Lbs

SCALE: 3/8" = 1'-0"

Oldcastle Precast[®]
 **UTILITY VAULT**[™] Division
 Southern California
 Fontana, San Diego, Santa Paula
 Phone: 800-626-3860 Fax: 909-428-3737

AZUSA 46672PB
 FILE NAME: 070UEE4666PBAZ.DWG
 ISSUE DATE: April 2002
www.oldcastleprecast.com

4'-0" X 6'-6" X 6'-0"
Deep Base Pull Box
City of Azusa

Copyright © 2008 **Oldcastle** Precast, Inc.