

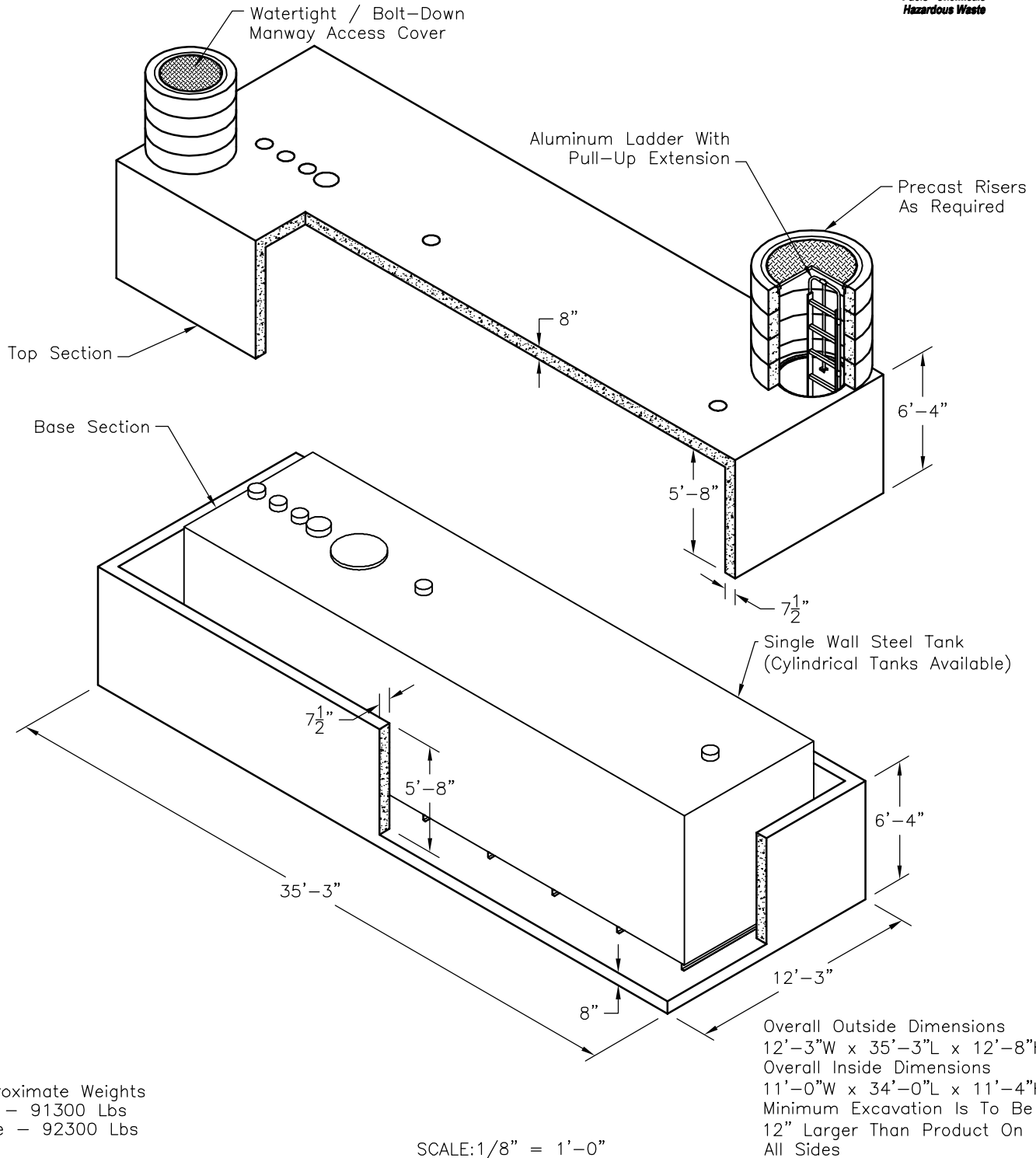

NOTE: Penetrations and Tank Dimensions Shown Are For Illustration Purposes Only. Actual Penetration Sizes & Locations and Tank Dimensions & Capacity Will Vary According To Customer's needs.



Oldcastle Precast
 UTILITY VAULT™ Division
 Southern California
 Fontana, San Diego, Santa Paula
 Phone: 800-626-3860 Fax: 909-428-3737

ContVlt 1134136CV

FILE NAME: 070UEE1134CVFV.DWG

ISSUE DATE: September 2001

www.oldcastleprecast.com

**11'-0" x 34'-0" x 11'-4"
 Secondary Containment
 Standard Layout**

Copyright © 2008 Oldcastle Precast, Inc.