

**PIPE DIMENSIONS & WEIGHTS**

ID	WT	JT	GD	BD	RD	RT	X	OD	WEIGHT (lbs/ft)	PLANT	AVAIL LENGTH
15"	B-2 1/4"	3 1/2"	18.759"	23 5/16"	18.229"	1.75"	5 3/4"	19 1/2"	135	RAL	8'
18"	B-2 1/2"	3 1/2"	21.787"	26 1/2"	21.257"	1.75"	5 3/4"	23"	178	RAL	8'
24"	B-3"	3 1/2"	27.100"	31 1/32"	26.570"	1.75"	4 3/8"	30"	267	RAL	8'
30"	B-3 1/2"	3 1/2"	34.000"	38 1/2"	33.470"	1.75"	5"	37"	388	RAL	8'
36"	B-4"	3 13/16"	40.316"	46.376"	39.791"	1.75"	6"	44"	536	RAL	8'

**PIPE DESIGN SPECIFICATIONS:**

1. ASTM C 76-LATEST CLASS III, IV, & V
2. AASHTO M-170-LATEST
3. MEETS ALL NCDOT SPECIFICATIONS

**JOINT DESIGN SPECIFICATIONS:**

1. ASTM C-443-LATEST (GASKET) OR ASTM C-990-LATEST (CONSEAL)

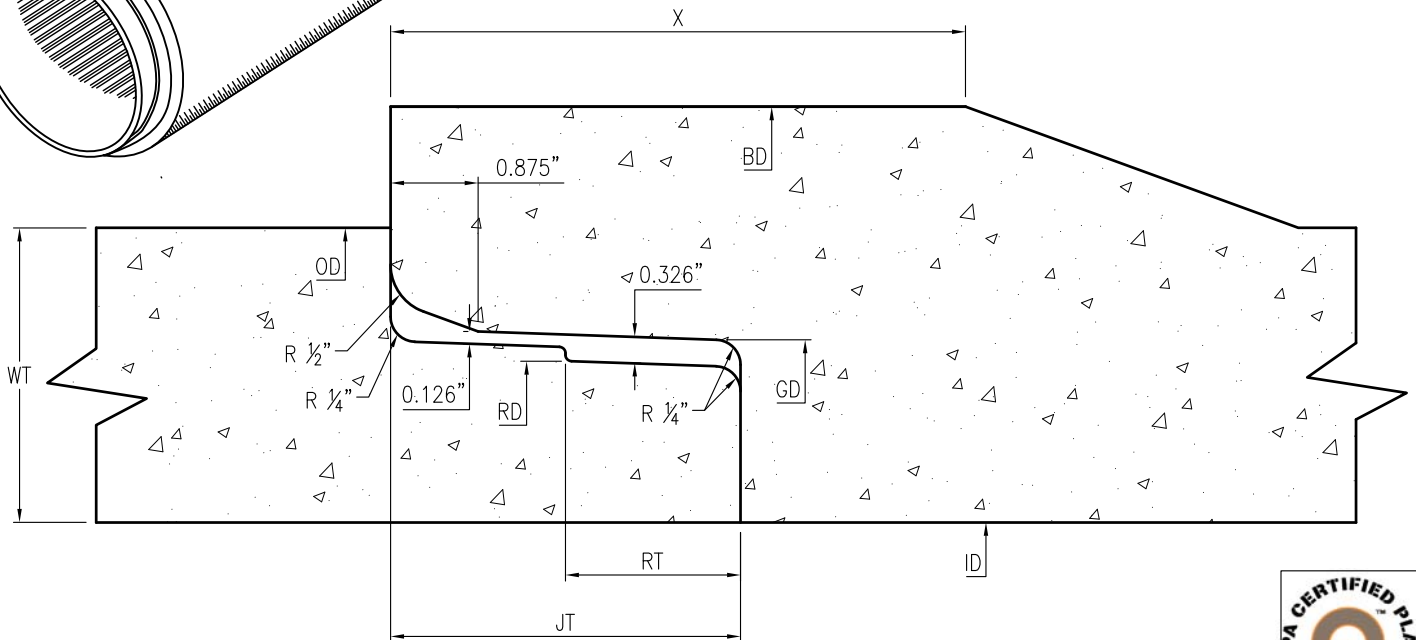
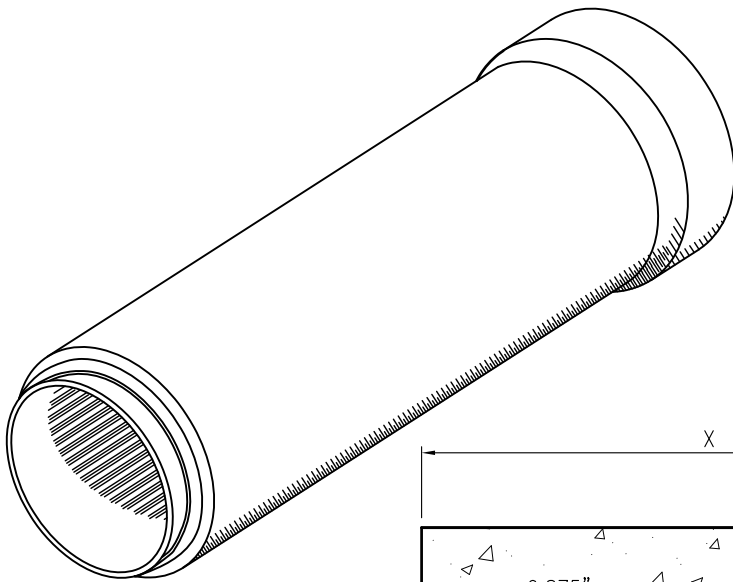

**JOINT DETAIL**  
SCALE:NTS



**TO ORDER PLEASE SPECIFY**

SIZE	CLASS	JOINT TYPE	JOINT SEALANT	LENGTH
		SO		8'
		SO		8'
		SO		8'

SIZE :  
INSIDE DIA. (INCH)

CLASS :  
C3, C4, C5

JOINT TYPE :  
TG= TONGUE & GROOVE  
SO= SINGLE OFFSET  
OR= O-RING

JOINT SEALANT:  
M= MORTAR  
C= CONSEAL CS-102  
S= SINGLE OFFSET  
GASKET

LENGTH:  
PER TABLE

**Oldcastle Precast®**  
920 WITHERS ROAD RALEIGH, NC 27603  
OFFICE 919-772-6301, FAX 918-772-1209

THIS DOCUMENT IS THE PROPERTY OF OLDCASTLE PRECAST, INC. IT IS CONFIDENTIAL, SUBMITTED FOR REFERENCE PURPOSES ONLY, AND SHALL NOT BE USED IN ANY WAY INJURIOUS TO THE INTERESTS OF, OR WITHOUT THE WRITTEN PERMISSION OF OLDCASTLE PRECAST, INC. COPYRIGHT © 2017 OLDCASTLE PRECAST, INC ALL RIGHTS RESERVED

**SINGLE OFFSET MODIFIED BELL PIPE**  
SUBMITTAL

CUSTOMER					
DATE 10/9/17	SALES	DRAWN PPS	ENGINEER	CHECKED	SALES ORDER
DRAWING NUMBER Single Offset Bell Pipe			REVISION	SHEET 1 OF 1	
			REV DATE		