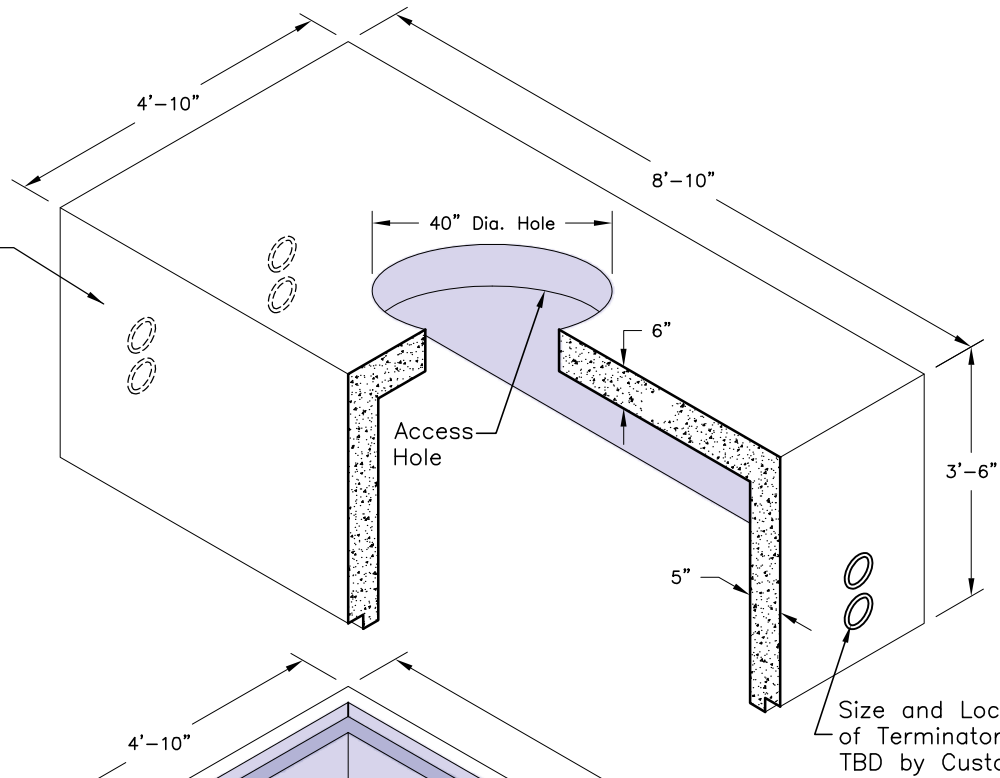
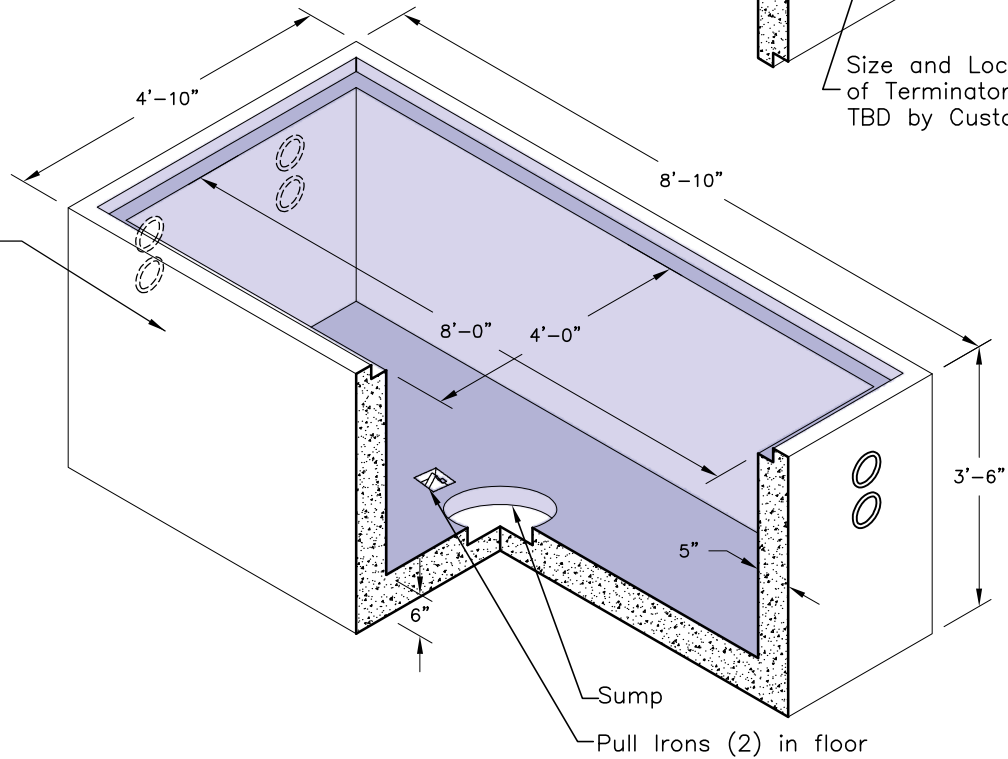

TOP SECTION
4896-T

Weight- 7,365 lbs.

BOTTOM SECTION
4896-B

Weight- 8,015 lbs.

SPECIFICATIONS:

1. Concrete: Design Strength of 5500 PSI at 28 Days.
2. Steel Reinforcement: ASTM A-615 Grade 60.
3. Loading: Designed for HS-20 Loading.
4. C.I. Castings: ASTM A-48 Class 30/35.

GENERAL NOTES:

1. Different Height Sections are Available on Request.
2. All Weights Calculated with Solid Walls.
3. Different Manhole Location & Opening Size Available.