

TOP SECTION
6060-T

Weight- See Table

TOP SECTION	
A	Weight
36"	7,150 Lbs.
48"	8,800 Lbs.
60"	10,450 Lbs.
72"	12,100 Lbs.

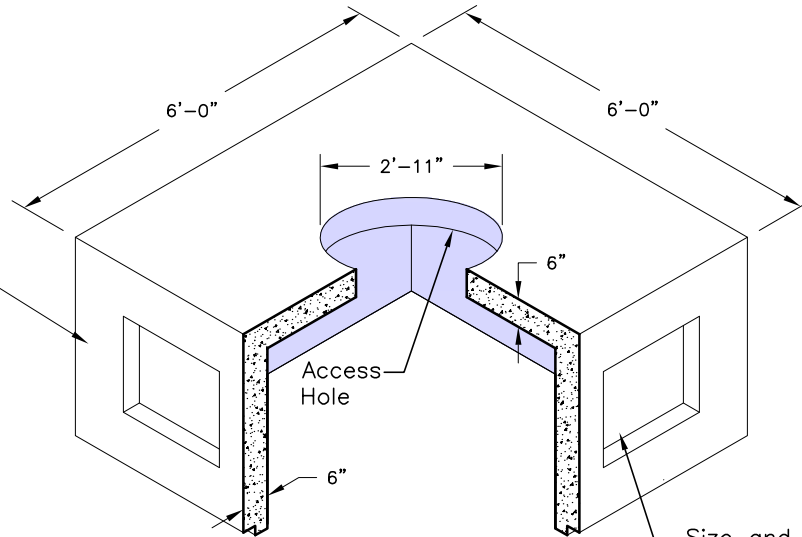

Size and Location of Knock Outs/Terminators TBD by Customer

BOTTOM SECTION
6060-B

Weight- See Table

BOTTOM SECTION	
A	Weight
36"	7,650 Lbs.
48"	9,300 Lbs.
60"	10,950 Lbs.
72"	12,600 Lbs.

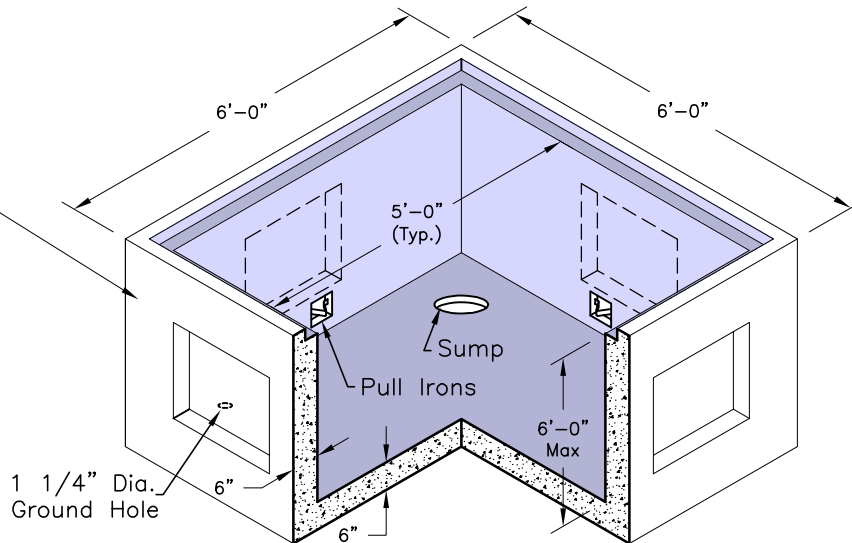
SPECIFICATIONS:

1. Concrete: Design Strength of 5500 PSI at 28 Days.
2. Steel Reinforcement: ASTM A-615 Grade 60.
3. Loading: Designed for HS-20 Loading.
4. C.I. Castings: ASTM A-48 Class 30/35.

GENERAL NOTES:

1. Different Height Sections are Available on Request.
2. All Weights Calculated with Solid Walls.
3. Access Manhole Location & Opening Size may vary.