

Top :

Weight : 3,690 Lbs.

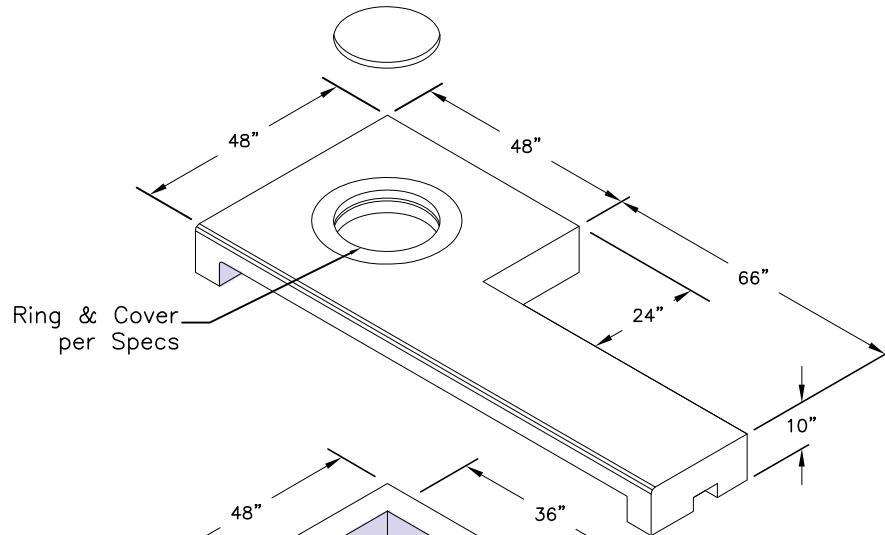
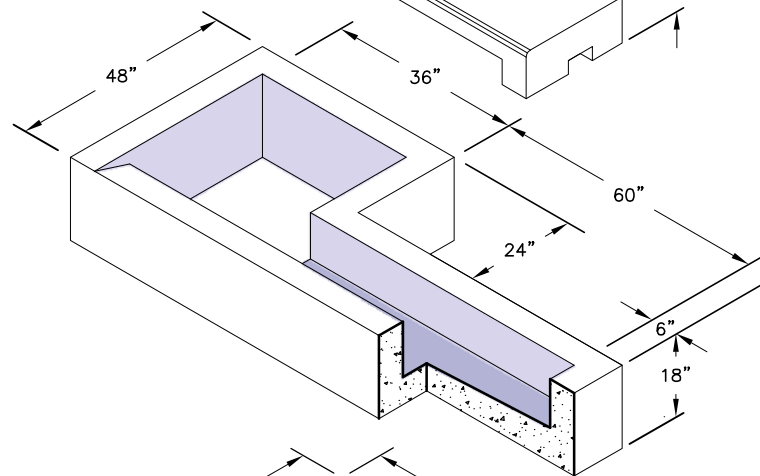

18" Mid-Section

Weight : 4,000 Lbs.

Variable Riser

Weight : See chart.

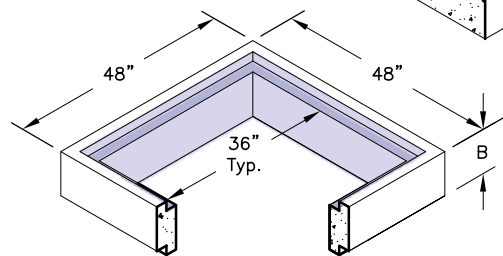
| Riser | |
|-------|---------------|
| B | Weight (Lbs.) |
| 6" | 495 |
| 12" | 1,000 |

Extension Options

Bottom :

Weight : See Chart

| Bottom | |
|---------|---------------|
| Wall(s) | Weight (Lbs.) |
| 4-Way | 3,220 |

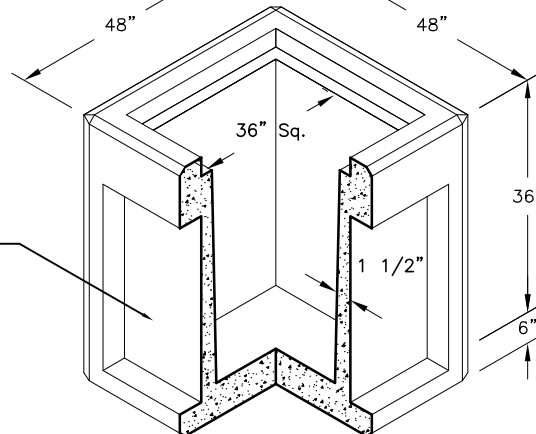
 Thinwall Knockout For
 24" R.C.P. or Smaller
 (Typical All Four Walls)

GENERAL NOTES:

1. Bedding Shall be in Accordance With Job and Plan Specifications.