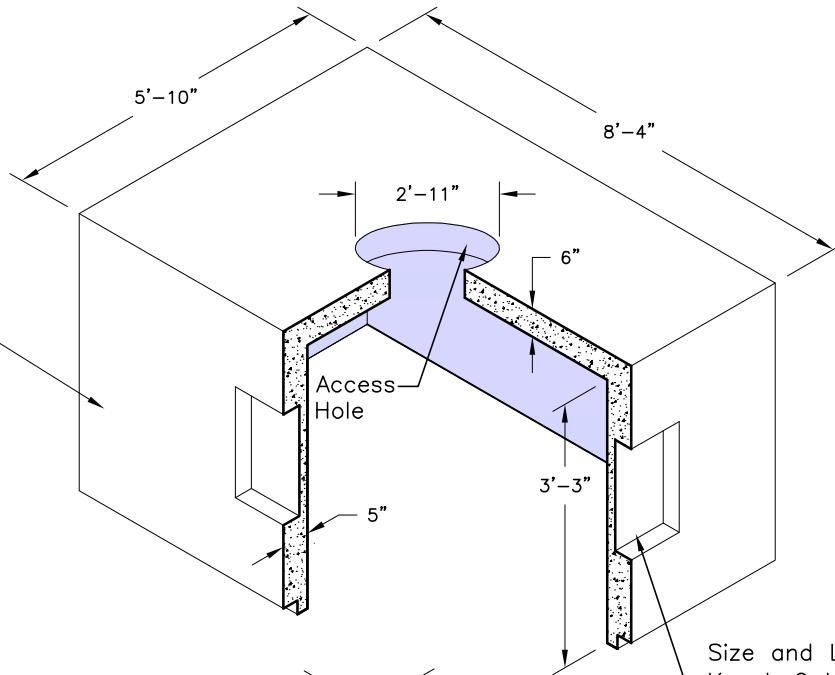
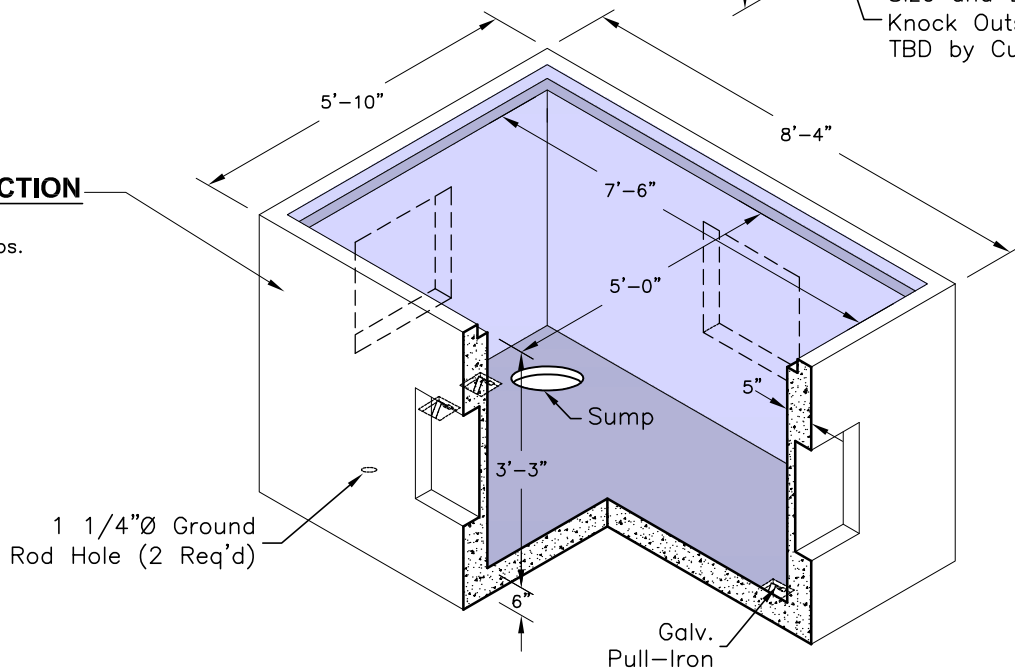

TOP SECTION
6090-T

Weight— 8,565 lbs.

BOTTOM SECTION
6090-B

Weight— 9,065 lbs.

SPECIFICATIONS:

1. Concrete: Design Strength of 5500 PSI at 28 Days.
2. Steel Reinforcement: ASTM A-615 Grade 60.
3. Loading: Designed for HS-20 Loading.
4. C.I. Castings: ASTM A-48 Class 30/35.

GENERAL NOTES:

1. Different Height Sections are Available on Request.
2. All Weights Calculated with Solid Walls.
3. Access Manhole Location & Opening Size may vary.