

**Type "P"
Safety-End-Treatment**

Variable (See Chart)

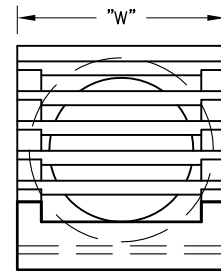
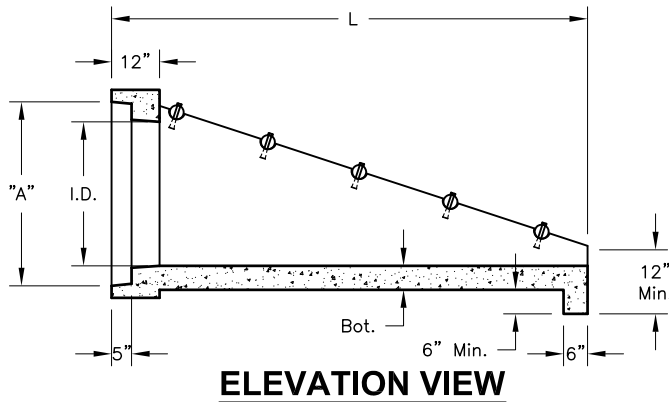

END VIEW

SPECIFICATIONS:

1. Concrete: Class "C" w/ design strength of 5000 PSI at 28 days.
2. Steel reinforcement: ASTM A-615 Grade 60 or ASTM A-497 Welded wire fabric.
3. Loading: Designed for H2O Loading.
4. C.I. Castings: ASTM A48, Class 30/35.
5. All exposed Corners shall be Chamfered 3/4".

Pipe I.D.	Slope	Weight	W	L	Wall	Bot.	A	Item#
36"	3:1	7,000 Lbs.	52"	119"	6"	6"	46"	1223340
	4:1	8,850 Lbs.	52"	154"	6"	6"	46"	1223380
	6:1	12,500 Lbs.	52"	228"	6"	6"	46"	1223460
42"	3:1	10,875 Lbs.	61"	142"	8"	6"	53"	1223500
	4:1	13,750 Lbs.	61"	186"	8"	6"	53"	1223540
	6:1	19,750 Lbs.	61"	276"	8"	6"	53"	1223580