

REV	DESCRIPTION	BY	DATE
A	ADDED "ADOT" TO GENERAL NOTES	FB	5/21/03
B	ADDED NEW TITLE BLOCK	AT	12/18/09
C	NCS UPDATE	CP	6/26/17

## STRUCTURAL NOTES

1. CONCRETE: 28 DAY COMPRESSIVE STRENGTH  $f_c = 5,000$  psi
2. REBAR: ASTM A-615 GRADE 60
3. MESH: ASTM A-1064 GRADE 65
4. DESIGN: ACI 318-14 BUILDING CODE  
ASTM C-857 "MINIMUM STRUCTURAL DESIGN LOADING FOR UNDERGROUND PRECAST CONCRETE UTILITY STRUCTURES"
5. LOADS: HS20-44 W/30% IMPACT PER AASHTO  
80 PSF LATERAL LIVE LOAD SURCHARGE - UP TO 8'-0" DEPTH  
SOIL: 40 PCF LATERAL SOIL PRESSURE ABOVE WATER TABLE  
80 PCF LATERAL SOIL PRESSURE BELOW WATER TABLE  
120 PCF SOIL DENSITY
6. SOIL COVER: NONE
7. WATER TABLE: 5'-0" BELOW GRADE

## GENERAL NOTES

1. CATCH BASIN TO BE CAST IN SECTIONS AS SHOWN FOR ALL HEIGHTS TO 6'-6" MAX. HEIGHTS OVER 6'-6" SHALL BE 2 SECTIONS. NO SECTION SHALL BE LESS THAN 12" IN HEIGHT. CONSEAL 1" JOINT SEALANT SHALL BE USED BETWEEN ALL SECTIONS.
2. MAXIMUM DEPTH: 8'-0"
3. GRATING SHALL BE FABRICATED OF STRUCTURAL STEEL.
4. STRUCTURAL STEEL SHALL BE IN ACCORDANCE WITH ASTM A36.
5. ALL WELDING SHALL BE IN ACCORDANCE WITH ADOT STANDARD SPECIFICATION 604-3.06.
6. GRATING ASSEMBLY SHALL BE GIVEN ONE SHOP COAT OF NO. 1 PAINT.
7. CONCRETE SHALL BE CLASS B IN ACCORDANCE WITH SECTION 1006 OF THE ADOT SPECIFICATIONS. NO. 1 PAINT.
8. GROUT SHALL BE NON-SHRINK & NON-METALLIC. THE TYPE SHALL BE APPROVED BY MATERIAL SERVICES.
9. THE "H" DIMENSION AS SPECIFIED ON THE PROJECT PLANS SHALL BE VERIFIED IN THE FIELD BEFORE CASTING.

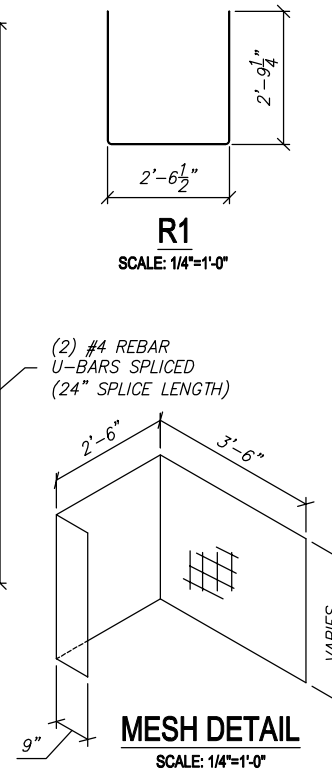
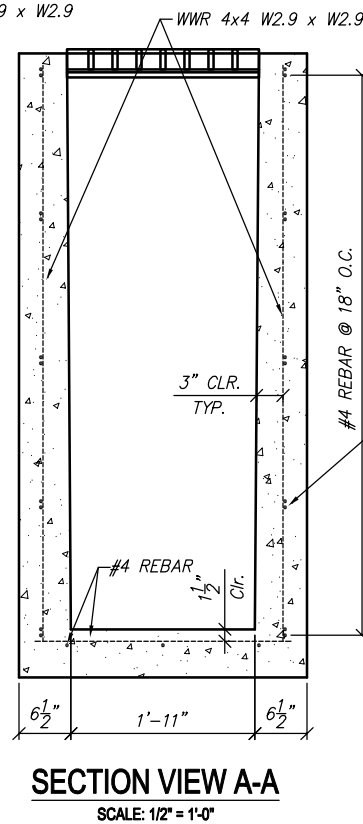
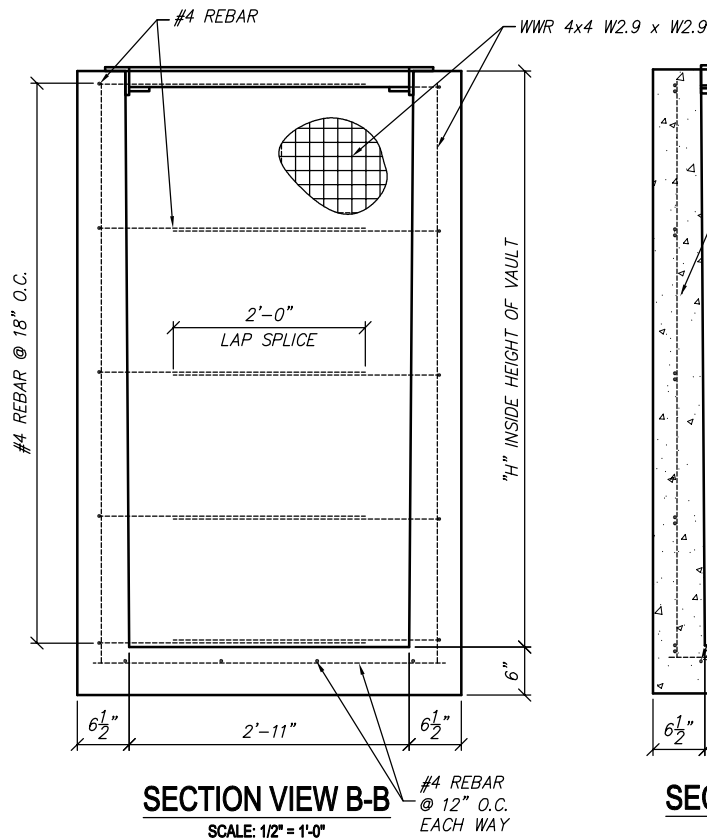
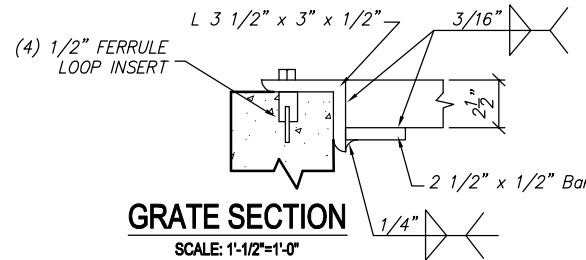
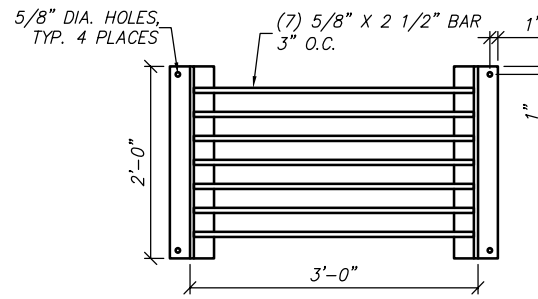
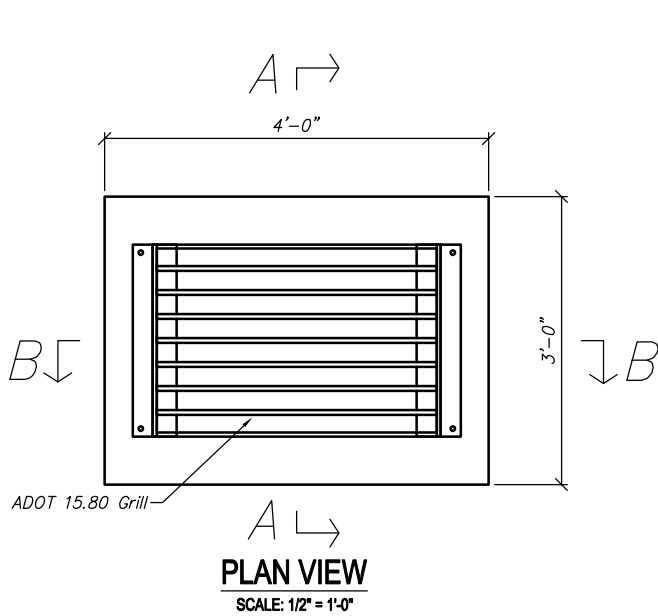

THIS DOCUMENT IS THE PROPERTY OF OLDCASTLE PRECAST, INC. IT IS CONFIDENTIAL, SUBMITTED FOR REFERENCE PURPOSES ONLY, AND SHALL NOT BE USED IN ANY WAY INJURIOUS TO THE INTERESTS OF, OR WITHOUT THE WRITTEN PERMISSION OF OLDCASTLE PRECAST, INC. COPYRIGHT ©2017 OLDCASTLE PRECAST, INC. ALL RIGHTS RESERVED

## 2 X 3 PRECAST CONCRETE CATCH BASIN

A.D.O.T. MODEL NO. C-15.80

CUSTOMER  
**STANDARD**

DATE	SALES	DRAWN	ENGINEER	CHECKED	SALES ORDER
3/25/02		AT			---
DRAWING NUMBER				REVISION	SHEET
U1100-1				B	1 OF 1
				REV DATE	