

**6'x15'
Vault**

6'x15' Utility Vault
Bottom, Riser and Top

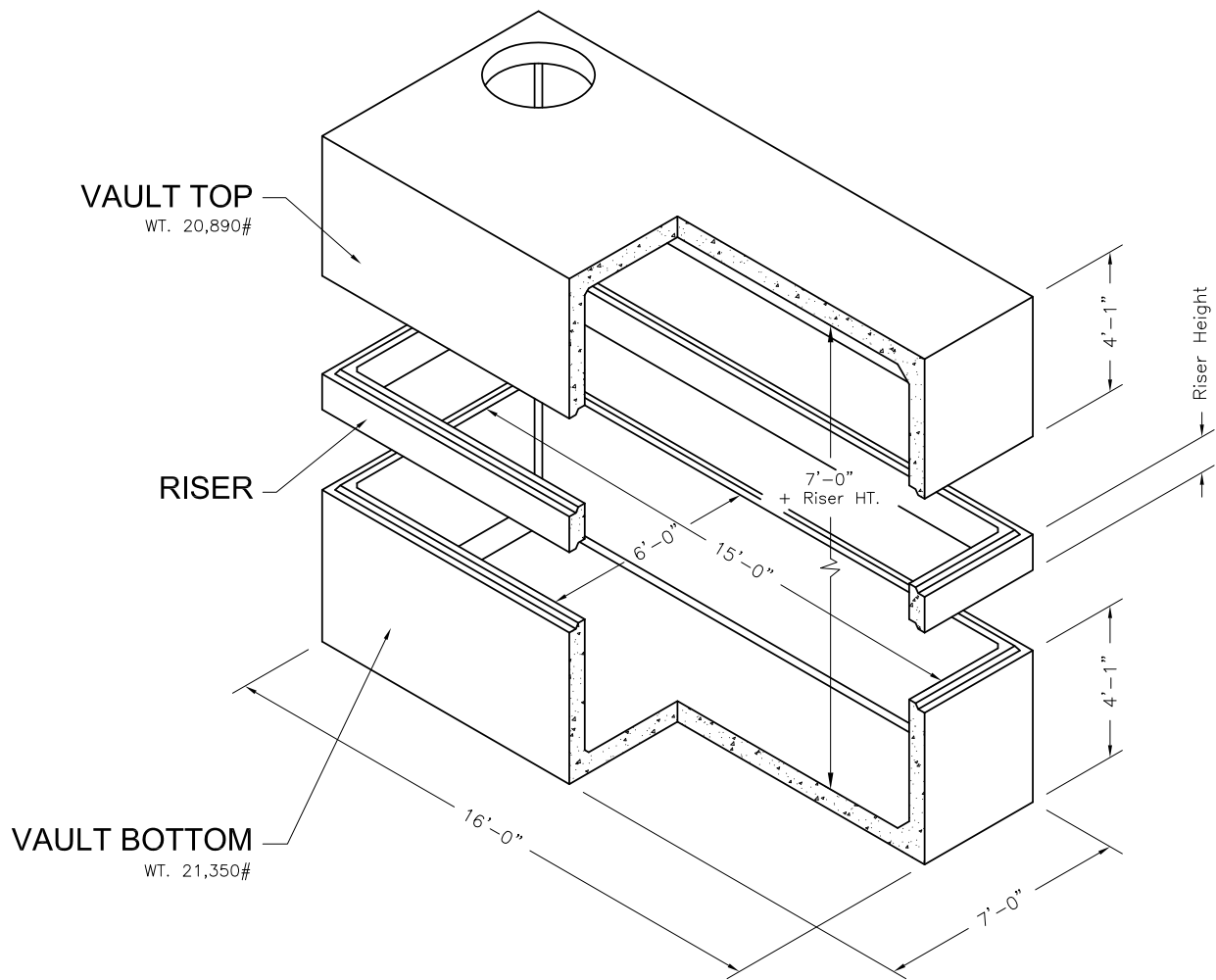

Riser

Height	Weight
1'	3,250#
2'	6,500#
3'	9,750#

- NOTES:
1. Vault design complies with ASTM C-857 and C-858 with less than 2' of earth cover and ar AASHTO HS-20 loading.
 2. Lifting insert type and location may change without notice.

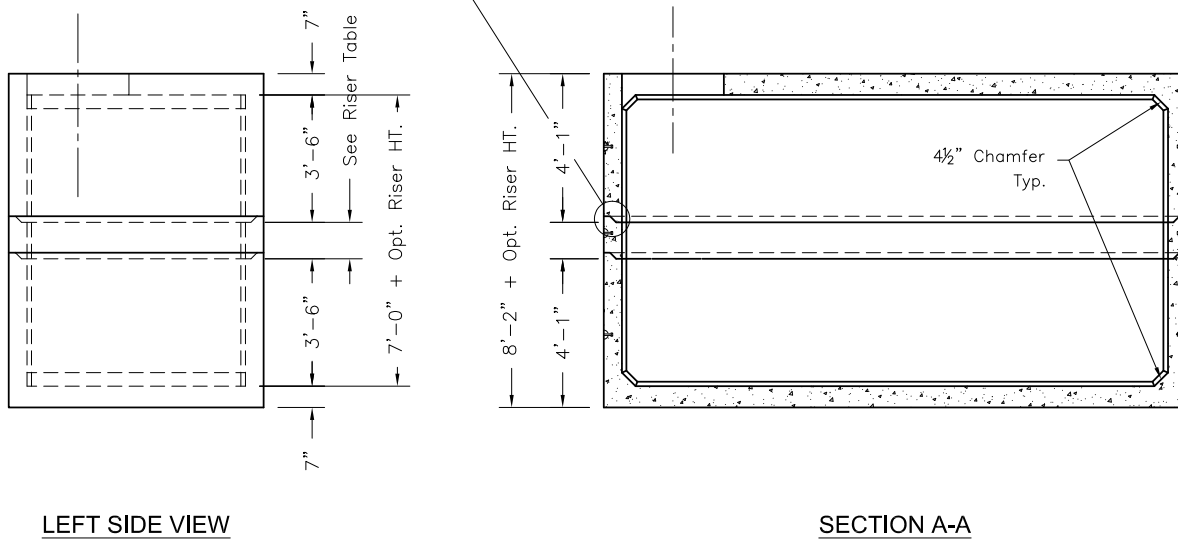
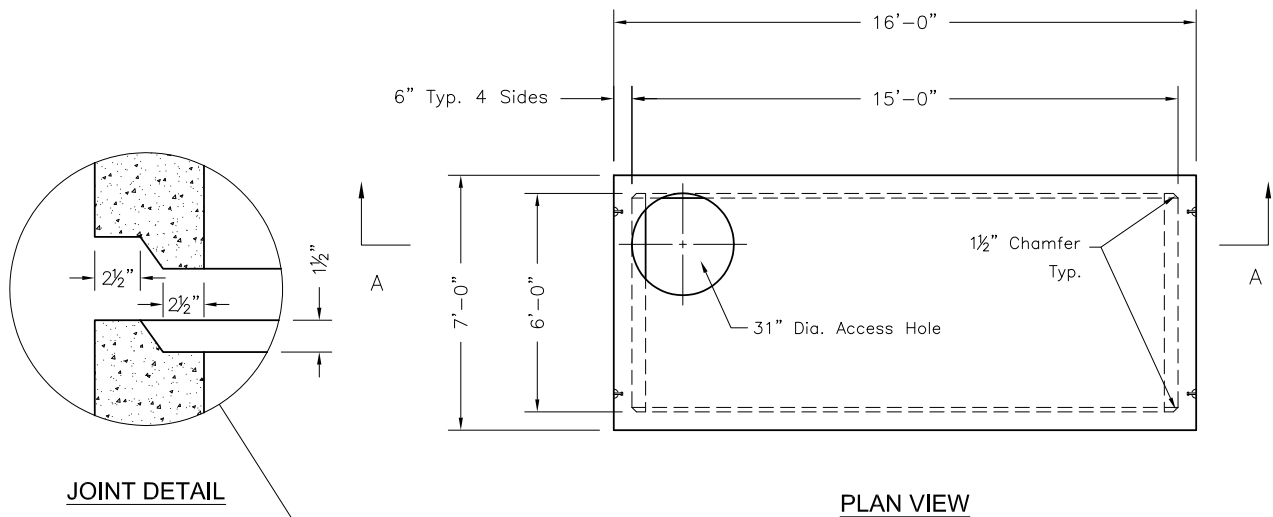

Oldcastle Precast
 801 West 12th Street
 Ogden, Utah 84404

Phone: (801) 399-1171
 Fax: (801) 392-7849

For more information about our products, please visit
oldcastleprecast.com

oldcastleprecast.com