

**8'x10'
Vault**

8'x10' Utility Vault
Bottom, Riser and Top

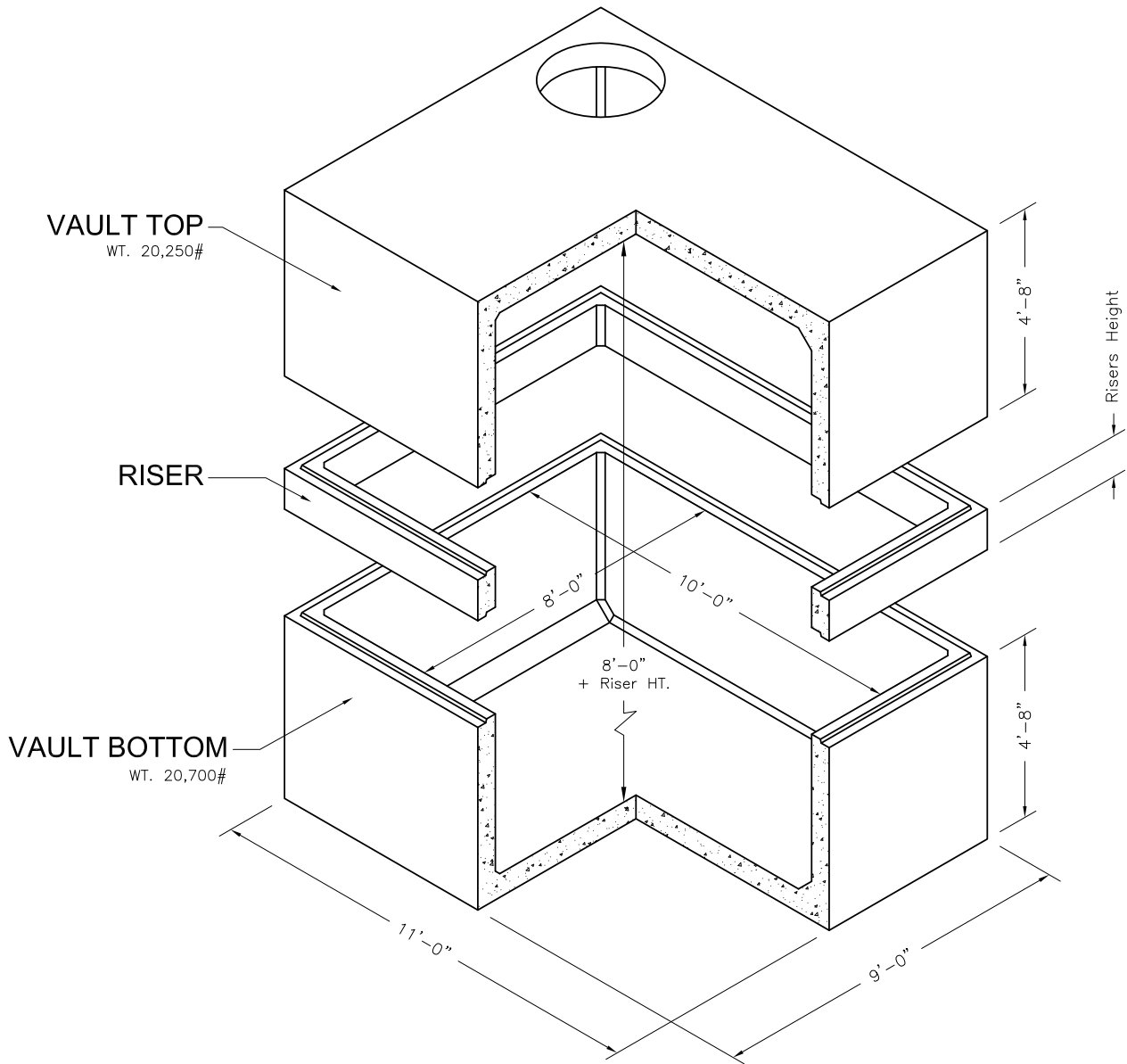

Riser

Height	Weight
2'	5,700#
3'	8,550#

NOTES:

1. Vault design complies with ASTM C-857 and C-858 with less than 2' of earth cover and ar AASHTO HS-20 loading.
2. Lifting insert type and location may change without notice.

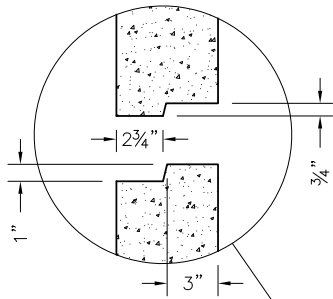

JOINT DETAIL

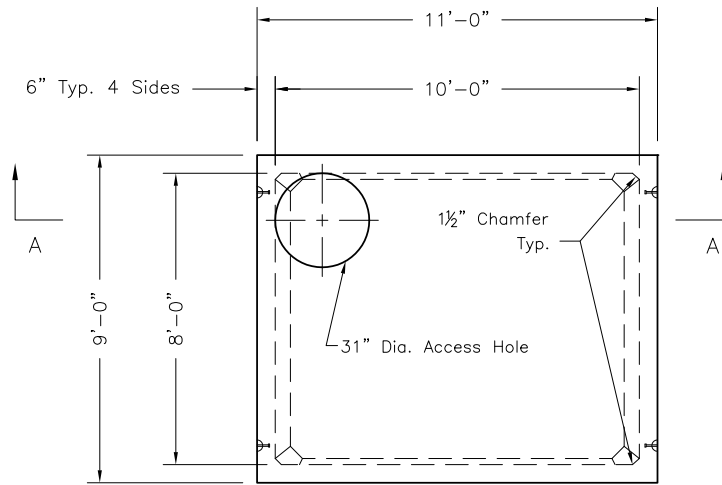

PLAN VIEW

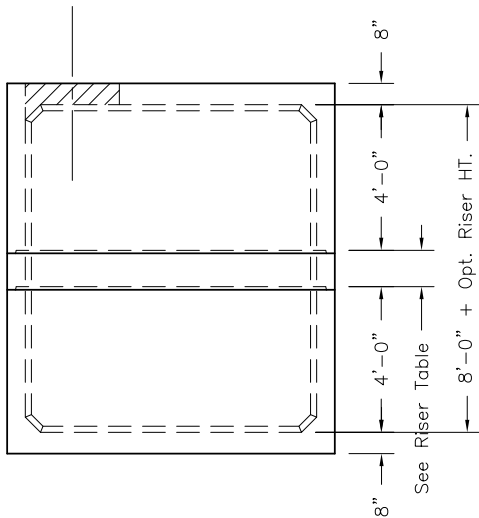

LEFT SIDE VIEW

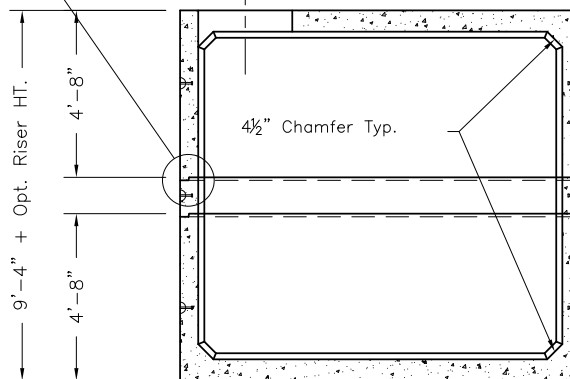

SECTION A-A

Oldcastle Precast
801 West 12th Street
Ogden, Utah 84404

Phone: (801) 399-1171
Fax: (801) 392-7849

For more information about our products, please visit
oldcastleprecast.com

oldcastleprecast.com