

**8'x12'
Vault**

8'x12' Utility Vault
Bottom, Riser and Top

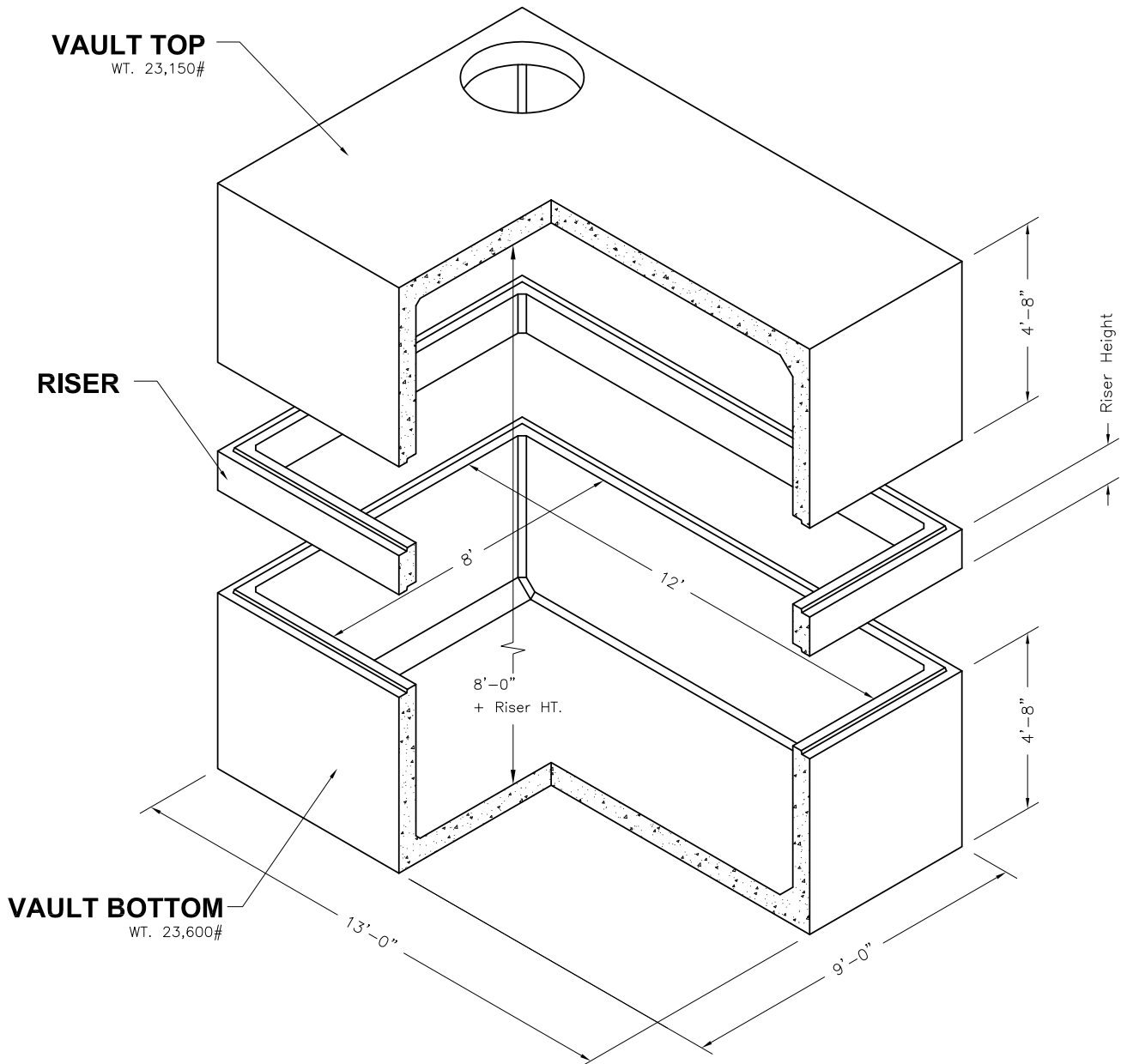

Riser	
Height	Weight
2'	6,400#
3'	9,600#

- NOTES:
1. Vault design complies with ASTM C-857 and C-858 with less than 2' of earth cover and ar AASHTO HS-20 loading.
 2. Lifting insert type and location may change without notice.

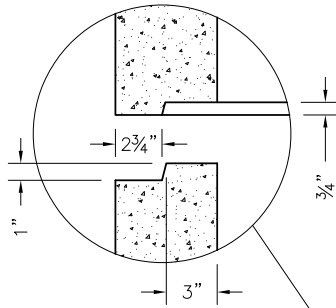

JOINT DETAIL

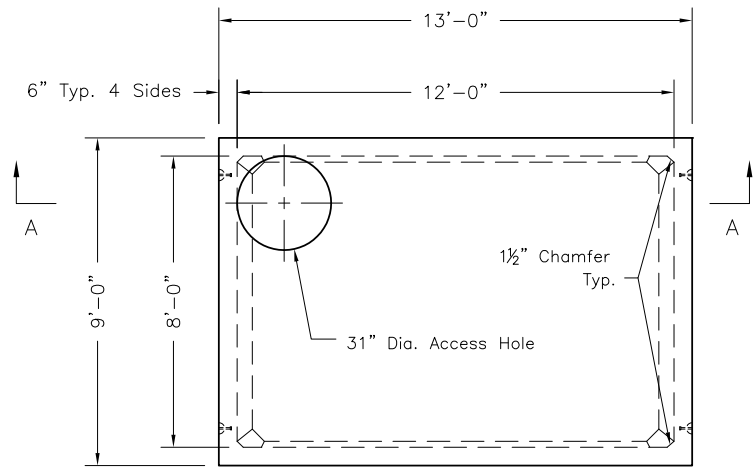

PLAN VIEW

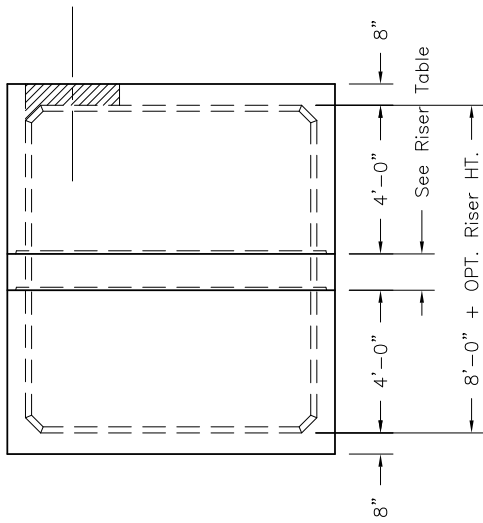

LEFT SIDE VIEW

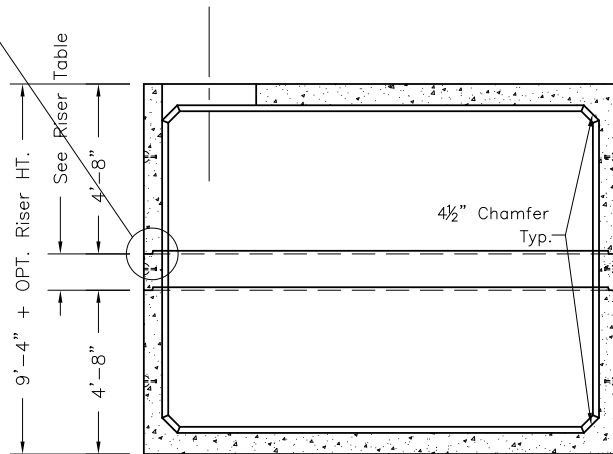

SECTION A-A

Oldcastle Precast
801 West 12th Street
Ogden, Utah 84404

Phone: (801) 399-1171
Fax: (801) 392-7849

For more information about our products, please visit
oldcastleprecast.com

oldcastleprecast.com