

# 8'x16' Vault

8'x16' Utility Vault  
Bottom, Riser and Top

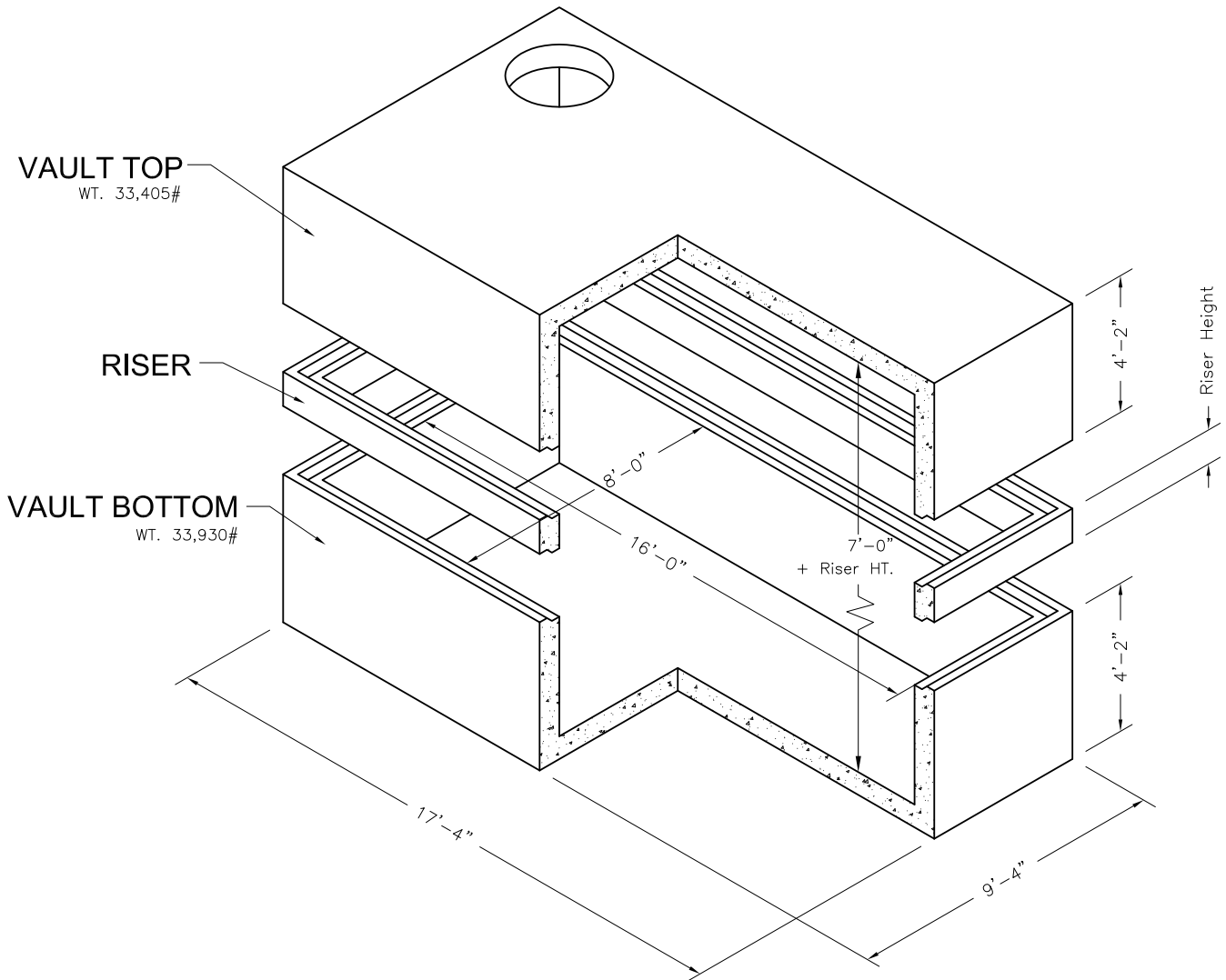

VAULT TOP  
WT. 33,405#

RISER

VAULT BOTTOM  
WT. 33,930#

Riser

Height	Weight
1'	5,070#
2'	10,140#
3'	15,210#

NOTES:  
1. Vault design complies with ASTM C-857 or C-858 with less than 2' of earth cover and AASHTO HS-20 loading.  
2. Lifting insert type and location may change.

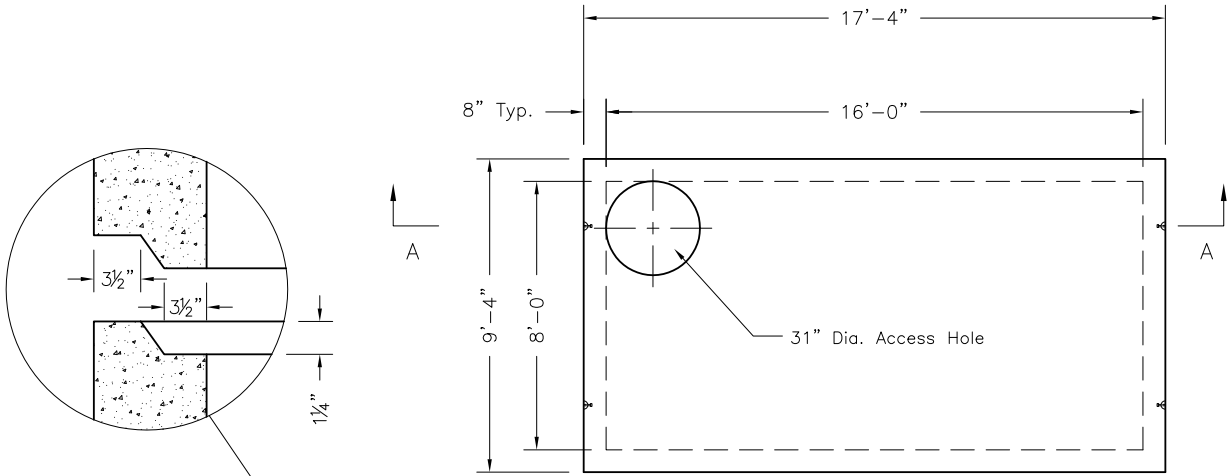

**JOINT DETAIL**

**PLAN VIEW**

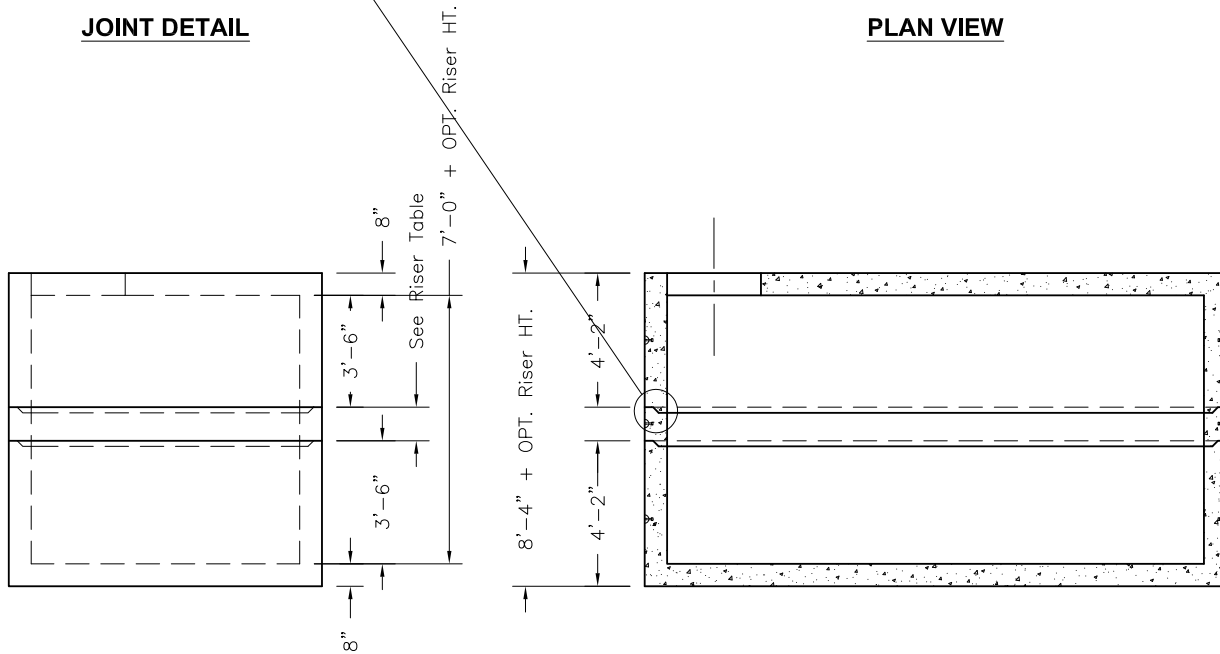

**LEFT SIDE VIEW**

**SECTION A-A**

**Oldcastle Precast**  
 801 West 12th Street  
 Ogden, Utah 84404

Phone: (801) 399-1171  
 Fax: (801) 392-7849

For more information about our products, please visit  
**oldcastleprecast.com**

*oldcastleprecast.com*