

REV	DESCRIPTION	BY	DATE
A	ADDED NEW TITLE BLOCK	AT	10/1/09
B	NCS UPDATES	CP	7/25/17

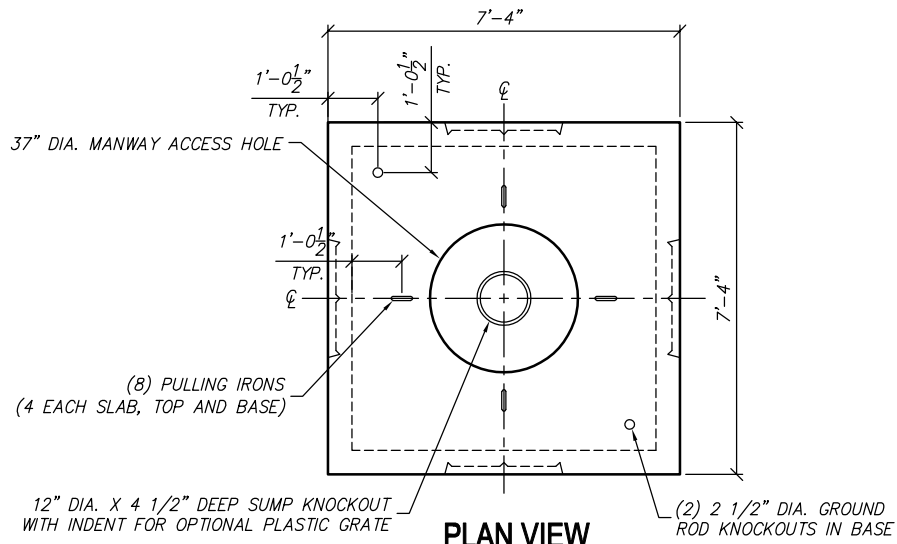

PLAN VIEW

SCALE: 1/4" = 1'-0"

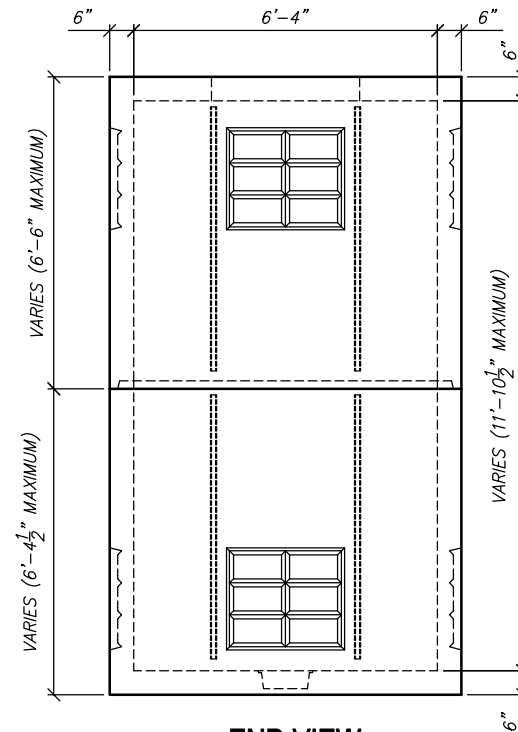

END VIEW

SCALE: 1/4" = 1'-0"

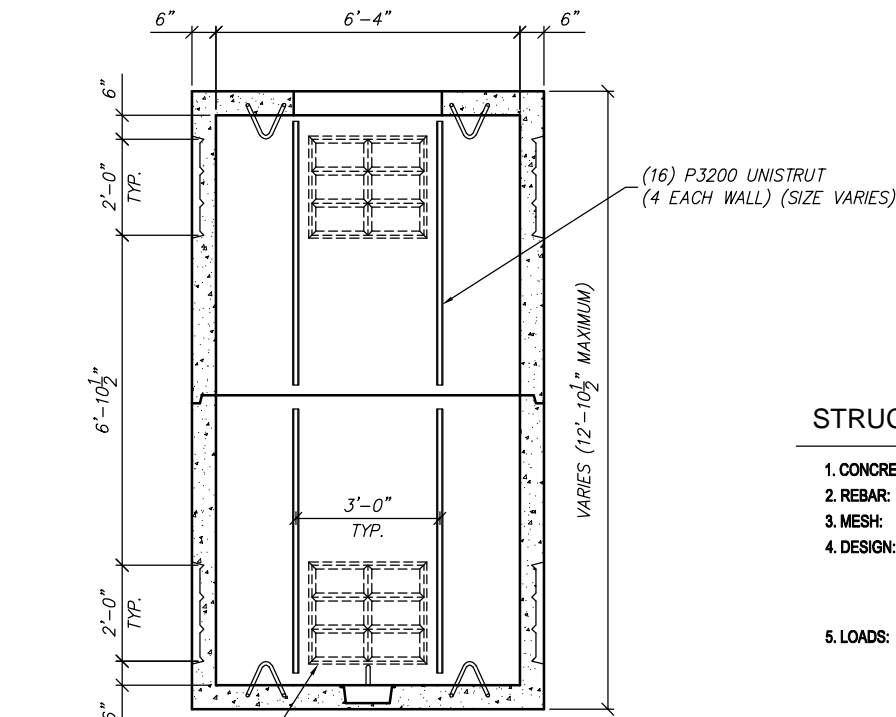

SECTION VIEW

SCALE: 1/4" = 1'-0"

STRUCTURAL NOTES

1. CONCRETE: 28 DAY COMPRESSIVE STRENGTH $f_c = 5,000$ psi
2. REBAR: ASTM A-615 GRADE 60
3. MESH: ASTM A-1064 GRADE 65
4. DESIGN: ACI 318-14 BUILDING CODE
ASTM C-857 "MINIMUM STRUCTURAL DESIGN
LOADING FOR UNDERGROUND PRECAST
CONCRETE UTILITY STRUCTURES"
5. LOADS: HS20-44 W/30% IMPACT PER AASHTO
80 PSF LATERAL LIVE LOAD SURCHARGE - UP TO 8'-0" DEPTH
SOIL: 40 PCF LATERAL SOIL PRESSURE ABOVE WATER TABLE
80 PCF LATERAL SOIL PRESSURE BELOW WATER TABLE
120 PCF SOIL DENSITY
6. SOIL COVER: 0' TO 5' (MAX.)
7. WATER TABLE: 5'-0" BELOW GRADE

GENERAL NOTES

1. ALL JOINTS SHALL BE SEALED USING CONSEAL CS-101 BUTYL RUBBER ROPE.



THIS DOCUMENT IS THE PROPERTY OF OLDCASTLE PRECAST, INC. IT IS CONFIDENTIAL, SUBMITTED FOR REFERENCE PURPOSES ONLY, AND SHALL NOT BE USED IN ANY WAY INJURIOUS TO THE INTERESTS OF, OR WITHOUT THE WRITTEN PERMISSION OF OLDCASTLE PRECAST, INC. COPYRIGHT ©2017 OLDCASTLE PRECAST, INC. ALL RIGHTS RESERVED

6464-LA (FULL HEIGHT)

CUSTOMER STANDARD					
DATE	SALES	DRAWN	ENGINEER	CHECKED	SALES ORDER
9/19/02	AT	AT			---
DRAWING NUMBER				REVISION	SHEET
V43L5-1				---	1 OF 1
				REV DATE	
