

8" Thick Precast Standard Catch Basin Tops (3 Req'd)  
Per D.C.W.A.S.A. Dwg. (sw/30.11)

**GENERAL NOTES:**

1. Concrete f'c = 5,000 psi.
2. Reinforcing Steel, ASTM A-615-84 Grade 60  
ASTM A-185 WWF Grade 72.5
3. Design Live Load = HS-20
4. Earth Cover = 0'-0" Min. to 0'-0" Max.
5. Contractor to:
  - Supply and Install All Piping
  - Knockout Openings as Needed and Grout in All Pipes.
6. Section Weights:
  - Top Slabs = 1,470 Lbs (.735 Tons) Ea.
  - Base = 12,750 Lbs (6.375 Tons)
  - Cheek Block Cnr. = 65 Lbs
  - Cheek Block Mid. = 130 Lbs

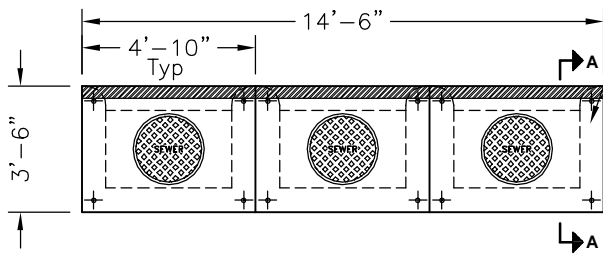

**SLAB PLAN VIEW**

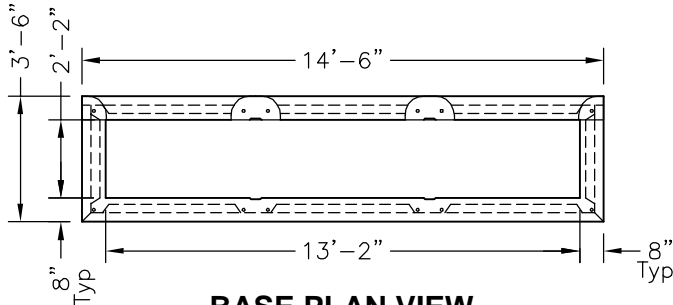

**BASE PLAN VIEW**

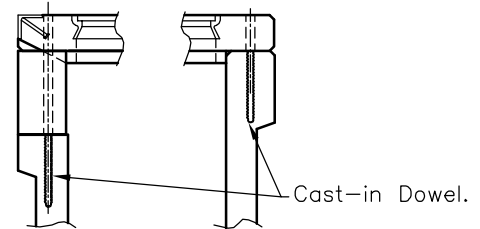

**SECTION A-A**

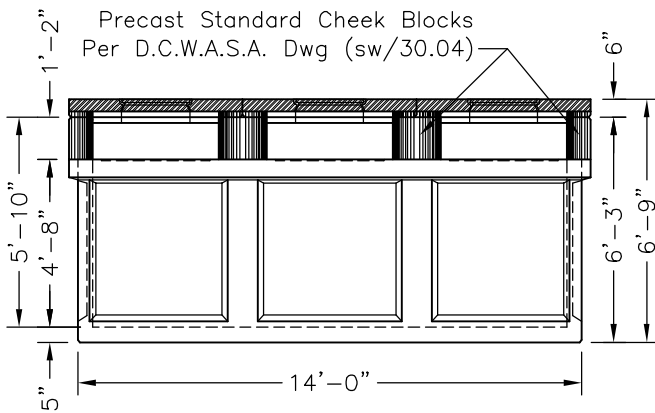

**FRONT ELEVATION**

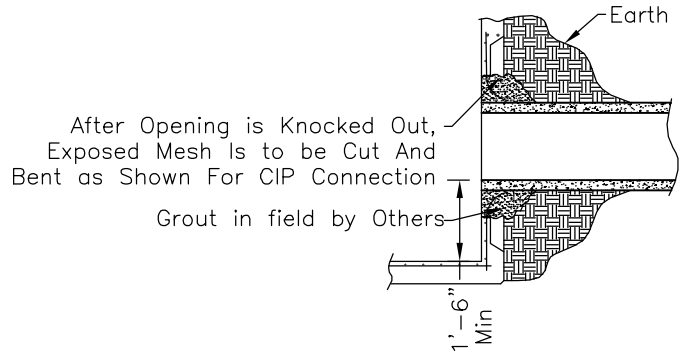

**PIPE CONNECTION DETAIL**

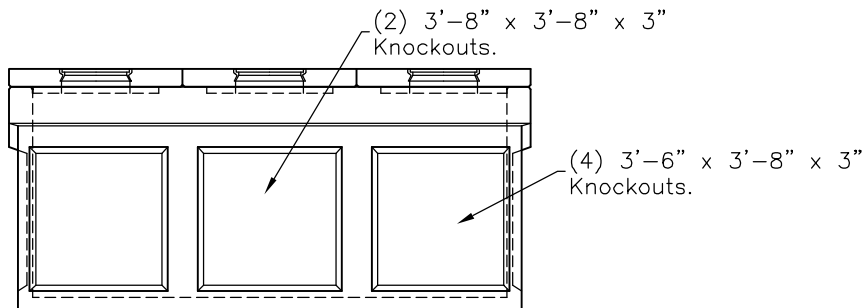

**REAR ELEVATION**

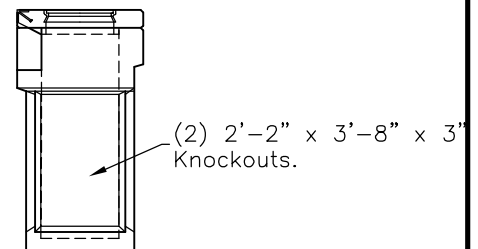

**END ELEVATION**

SCALE: 3/16" = 1'-0"



5115 Massaponax Church Road. Fredericksburg, Virginia  
Phone: 540.898.6300 Fax: 540.898.2389

**WASA-22132-TB**

FILE NAME: 365DICTRPCB

ISSUE DATE: January, 2003

**D.C.W.A.S.A. Triple  
Catch Basin**

Copyright © 2003 Oldcastle Precast