

NexGen 0018D

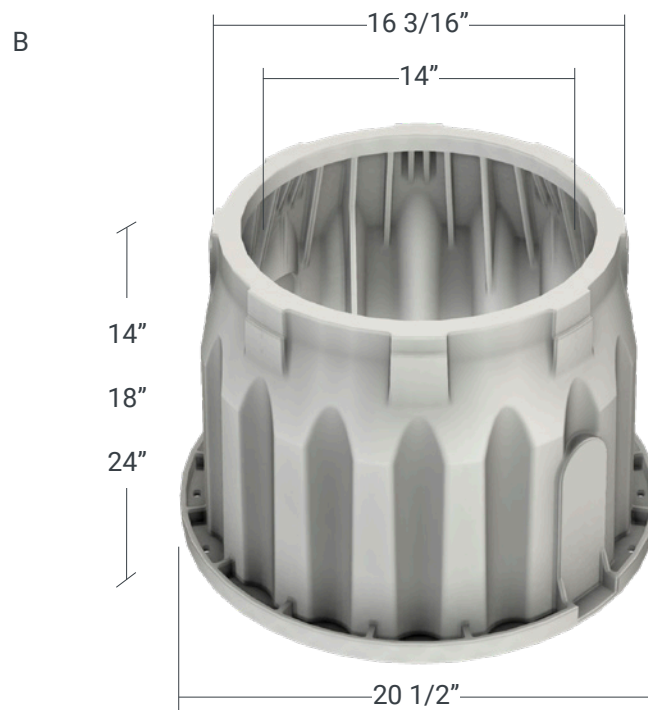
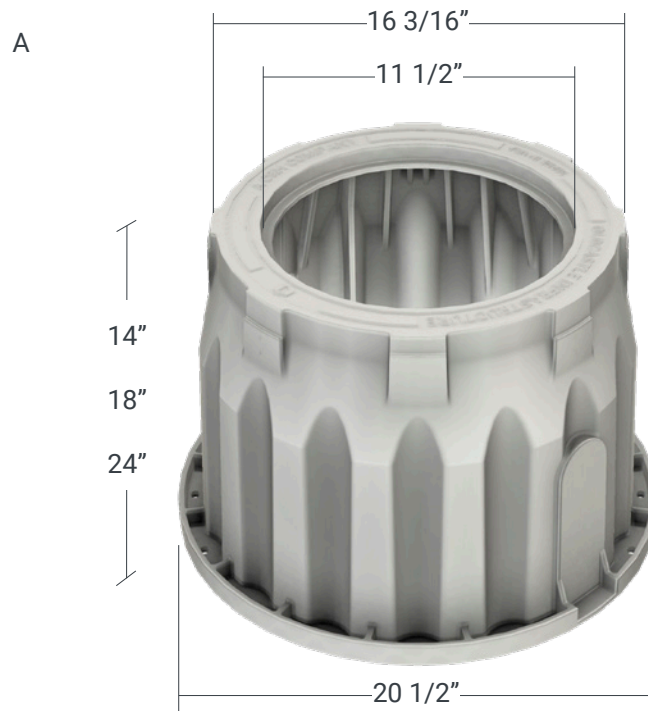

Material & Style

HDPE

Straight Wall, Fluted

White

(A) With Lid Seat

(B) Without Lid Seat*

0018D-14

(A) 9.8 lbs

(B) 9.0 lbs

0018D-18

(A) 9.8 lbs

(B) 10.9 lbs

0018D-24

(A) 14.0 lbs

(B) 12.7 lbs

Options

Mouseholes

Performance

20,000 lbs Vertical Loading

For use in non-vehicular traffic situations only. Weights and dimensions may vary slightly. Actual load rating is determined by the box and cover combination.

*Requires Ring and Cover

NexGen 0018D



Options

Available Covers:
(for models
with Lid Seat)

- HDPE, Flush Solid
- HDPE, Flush with AMR



Ring and Cover:
(for models
without Lid Seat)

- Cast Iron, Ring and HDPE Cover
- Cast Iron, Ring and Cast Iron Cover

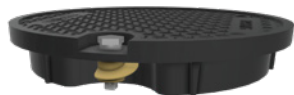

Add On Options

- Worm Gear Hardware (HDPE Covers)
- Dallas Lock (HDPE Covers)

Raw Material Specification

Material Property	Test Method	Typical Value ¹
Tensile Strength	ASTM D638	≥ 3,000 psi
Flexural Modulus	ASTM D790	120,000 min, not to exceed 240,000 psi
Chemical Resistance	ASTM D543	Very Resistant
Water Absorption	ASTM D570	Less than 2% weight change
UV Resistance	ASTM G154	Retention of 75% of physical properties after 1,000 hrs

¹ The values listed for physical property measurements are nominal values only. Certain physical property measurements are subject to variations consistent with the test methods and are within a generally accepted range for such values.

WARNING: Cancer - www.P65Warnings.ca.gov

All information contained on this sheet is current at the time of publication.
Oldcastle reserves the right to discontinue or update product information without notice.

© 2023 Oldcastle Infrastructure, Inc.