

Precast Concrete 60" Dia. Sanitary Manhole

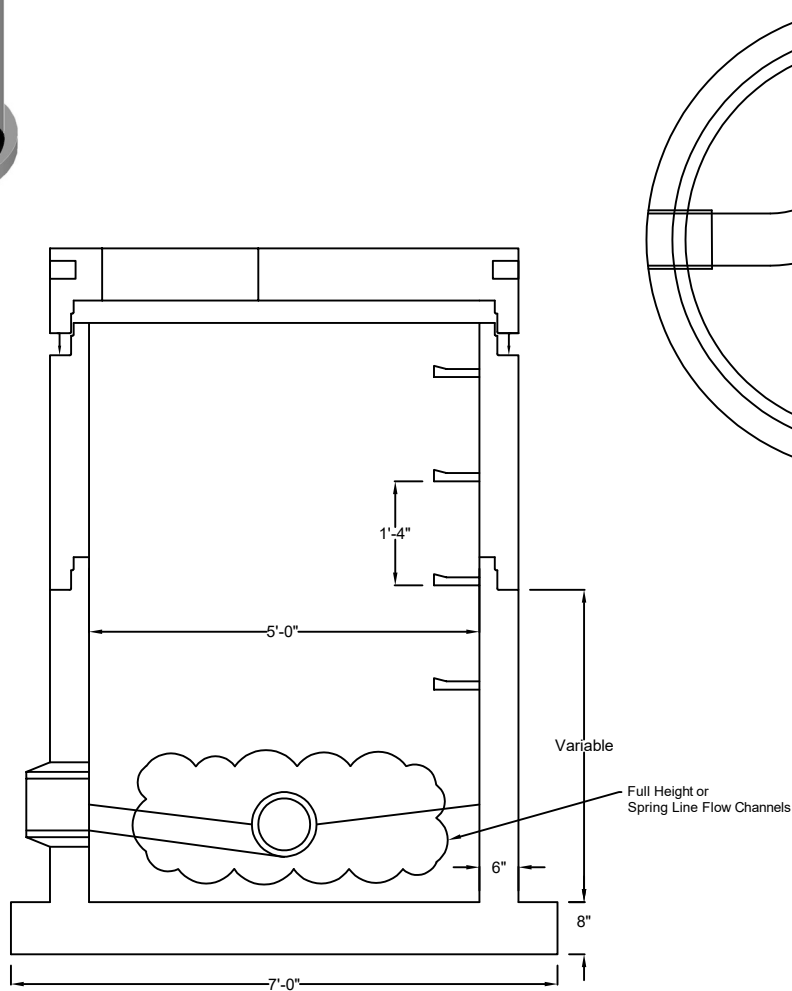

Standard Features

- 4500 PSI Concrete @ 28 Days
- Conforms to ASTM C-478
- Design for H-20 Traffic Loading
- Manufactured in NPCA Certified Plant

Standard Options

- Gasket Joint
- Cast Iron Frame and Cover
- 1", 2", 3" Precast Adjustment Rings
- Pipe Inlet/Outlet Holes Where Specified
- Booted Pipe Connection



7800 Adobe Rd.
Kalamazoo, MI 49009
269-342-0539

www.qualityprecastinc.com