

(530) 243-2562
FAX (530) 243-6881
www.cookconcreteproducts.com
e-mail:
Info@cookconcreteproducts.com

5461 EASTSIDE ROAD
P.O. BOX 720280
REDDING, CA 96099

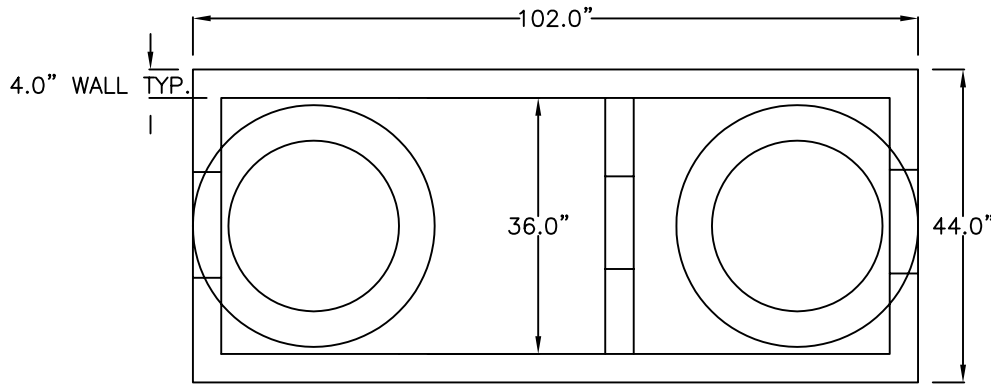

PLAN VIEW

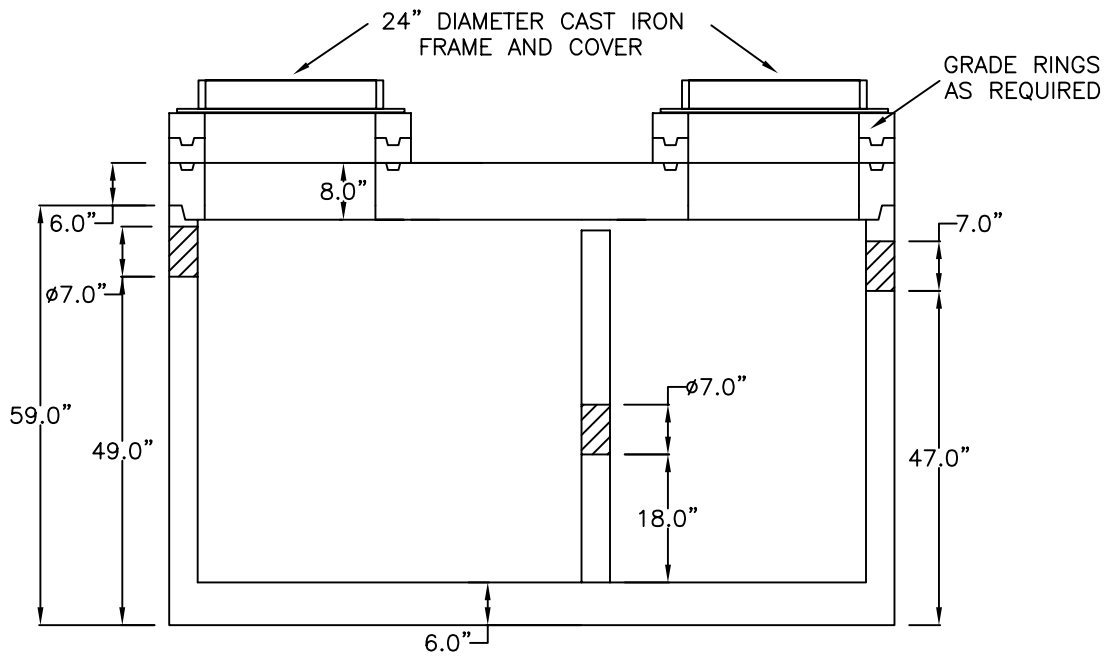

PROFILE

- DESIGNED FOR HS - 20 HIGHWAY LOADING (0' to 8' COVER)
- INLET & OUTLET SIZED AND LOCATED AS REQUIRED

500 GALLON GREASE INTECEPTOR