

STRUCTURE PROPERTIES	
STRUCTURE ID	1
MODEL SIZE	HSA-6S
TREATMENT FLOW RATE (cfs)	0.98
PEAK FLOW RATE (cfs)	15
SEDIMENT STORAGE (cu. yd.)	1.6

NOTES:

- LIVE LOADING CRITERIA:
 - AASHTO HS-20-44 (WITH IMPACT)
 - LATERAL LIVE LOAD SURCHARGE: 80 PSF (TO 8.00 FT DEPTH)
 - NO LATERAL SURCHARGE FROM ANY ADJACENT BUILDINGS, WALLS, FOUNDATIONS, OR ANY ADDITIONAL SITE ELEMENTS.
- SOIL LOADING CRITERIA:
 - SOIL COVER DEPTH: 0.50 FT (MIN.) - 5.00 FT (MAX.)
 - SOIL UNIT WEIGHT: 120 PCF
 - ASSUMED WATER TABLE ELEVATION: BELOW BOTTOM OF PRECAST
 - REQUIRED ALLOWABLE BEARING PRESSURE: 2,500 PSF
 - EQUIVALENT LATERAL FLUID PRESSURE: 45 PCF (ACTIVE)
 - SEISMIC LATERAL EARTH PRESSURES: NOT APPLICABLE
- CONCRETE (NORMALWEIGHT):
 - MIN. 28-DAY COMPRESSIVE STRENGTH: 6,000 PSI
 - CEMENT: ASTM C150
- STEEL REINFORCEMENT: ASTM A615 / A706 (GRADE 60)
- REFERENCE STANDARDS: ASTM C890& C913, ACI 318-14
- THIS STRUCTURE IS DESIGNED TO THE PARAMETERS NOTED HEREIN. ENGINEER-OF-RECORD SHALL VERIFY FY THAT NOTED PARAMETERS MEET OR EXCEED PROJECT REQUIREMENTS. IF DESIGN PARAMETERS ARE INCORRECT, REVIEWING ENGINEER/AUTHORITY SHALL NOTIFY OLDCASTLE INFRASTRUCTURE UPON REVIEW OF THIS SUBMITTAL.
- OVERSIZED HOLES TO ACCOMMODATE SPECIFIC PIPE TYPE MUST BE CONCENTRIC TO PIPE ID. AFTER PIPES ARE INSTALLED, ALL ANNULAR SPACES SHALL BE FILLED WITH A MINIMUM OF 3,000 PSI CONCRETE FOR FULL THICKNESS OF PRECAST WALLS. PIPES ARE TO BE FLUSH WITH THE INSIDE SURFACE OF THE CONCRETE STRUCTURE.
- CONTRACTOR RESPONSIBLE TO VERIFY ALL SIZES, LOCATIONS, AND ELEVATIONS OF OPENINGS.
- CONTRACTOR RESPONSIBLE TO ENSURE ADEQUATE BEARING SURFACE IS PROVIDED (I.E. COMPACTED AND LEVEL PER PROJECT SPECIFICATIONS).
- SECTION HEIGHTS, SLAB/WALL THICKNESSES, AND KEYWAYS ARE SUBJECT TO CHANGE AS REQUIRED FOR SITE REQUIREMENTS AND/OR DUE TO PRODUCT AVAILABILITY AND PRODUCTION FACILITY CONSTRAINTS.
- MAXIMUM PICK WEIGHTS":
 - TOP: # LBS
 - BASE: # LBS*
(* COMBINED WEIGHT OF BASE INCLUDES PRODUCT INTERNALS.)
- THE CONTRACTOR IS RESPONSIBLE FOR SETTING AND SECURING THE HSA UNIT ASSEMBLY TO THE PRE-INSTALLED LEDGER ANGLE BRACKETS USING THE PROVIDED HARDWARE. ADDITIONALLY, THE CONTACTOR MUST ENSURE THE SUPPLIED GASKET IS APPLIED BETWEEN THE FACE OF THE OUTLET MODULE AND THE MANHOLE WALL TO ENSURE PROPER SEALING AND PREVENT LEAKAGE.

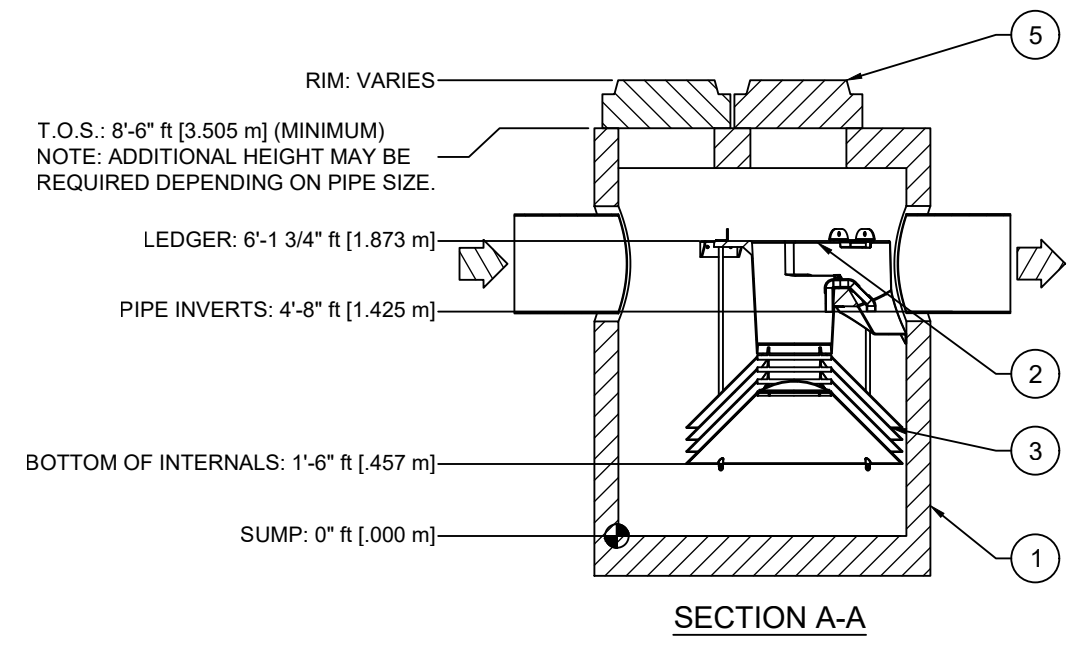
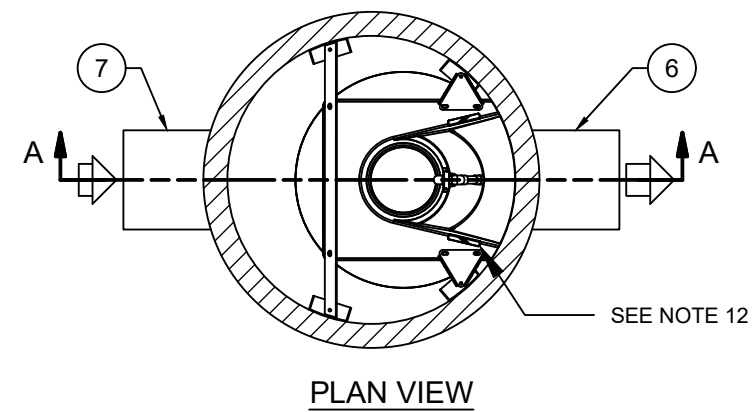

BILL OF MATERIALS						
ITEM	DESCRIPTION	BY	INSTALL	QTY	UNIT	SIZE & TYPE
1	6FT PRECAST MANHOLE	OI	GC	1	EA	
2	OUTLET MODULE	OI	OI	1	EA	
3	TREATMENT MODULE	OI	OI	1	EA	
4	GRADE RING(S)	GC	GC	1	EA	
5	FRAME & COVER	OI	GC	2	EA	24"Ø/ NF-0320-105
6	OUTLET PIPE	GC	GC	1	EA	24"Ø MAX
7	INLET PIPE	GC	GC	1	EA	24"Ø MAX

PROJECT NAME:		DATE:		PROJECT #:		SALES ORDER:	
HYDRO-SHIELD ADVANCE™ HSA-6S	CUSTOMER:	SPECIFIER DRAWING					
 Oldcastle Infrastructure <small>A CH2M COMPANY</small> <small>Ph: 888.865.3227 www.oldcastleinfrastructure.com/oldcastle</small>	THIS DOCUMENT IS THE PROPERTY OF OLDCASTLE INFRASTRUCTURE, INC. IT IS CONFIDENTIAL. SUBMITTED FOR REFERENCE PURPOSES ONLY AND SHALL NOT BE USED IN ANY WAY INJURIOUS TO THE INTERESTS OF, OR WITHOUT THE WRITTEN PERMISSION OF OLDCASTLE INFRASTRUCTURE, INC. COPYRIGHT © 2024 OLDCASTLE INFRASTRUCTURE, INC. ALL RIGHTS RESERVED.						
SHEET 1 OF 1							