

COOK CONCRETE PRODUCTS, INC.

—Precast—



MANHOLE PIPE • DRAINAGE INLETS • STORM WATER/OIL INTERCEPTORS • UTILITY VAULTS & BOXES • CUSTOM PRECAST

(530) 243-2562
 FAX (530) 243-6881
 www.cookconcreteproducts.com
 e-mail: Info@cookconcreteproducts.com

5461 EASTSIDE ROAD
 P.O. BOX 720280
 REDDING, CA 96099

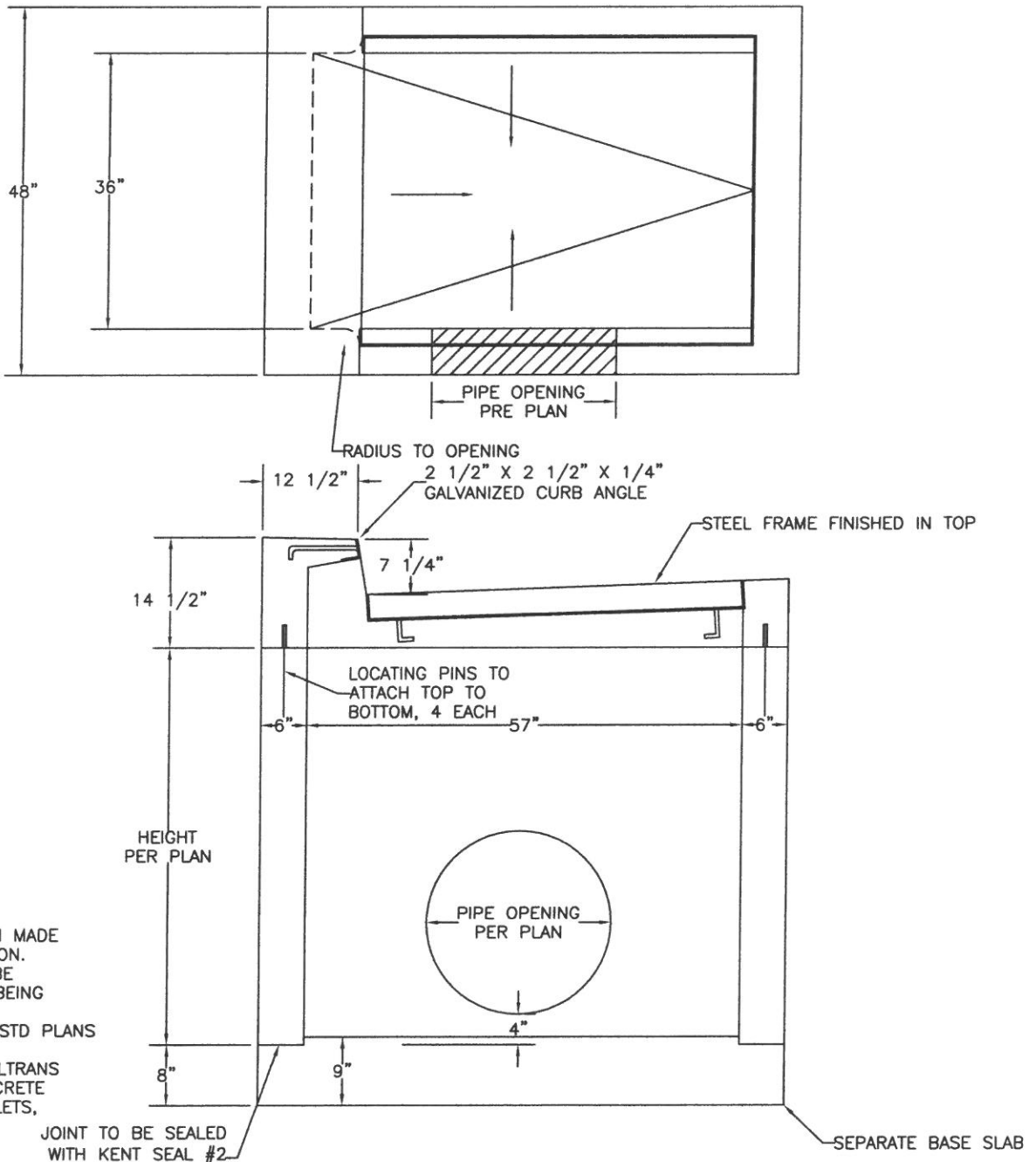

- NOTES:
1. UNITS ARE CUSTOM MADE FOR EACH LOCATION.
 2. OPENINGS SHALL BE SIZED FOR PIPE BEING USED.
 3. REINFORCING PER STD PLANS D73-E, F & G
 4. CONCRETE PER CALTRANS STRUCTURAL CONCRETE FOR DRAINAGE INLETS, 5,000 psi.

CALTRANS TYPE GDO INLET

AMERICA PACIFIC
6 EACH
CT # 05A2158