

# Grit King®

## All Hydraulic Grit Separation

### Product Summary

#### Low headloss with phenomenal performance

The Grit King® is an advanced hydrodynamic separator that augments gravitational forces to separate grit from water. The Grit King® is an economical choice for new or existing municipal or industrial wastewater applications.

### Performance

- » Removes 95% of particles equal to or greater than 75 microns at the design flow rate
- » Less than 20% volatile solids and greater than 60% total solids when paired with a Hydro washing and dewatering system
- » Typically less than 12 inches (30 cm) headloss at peak flow and less than 6 inches (15 cm) at average daily flow

### Capacity

- » Single units can handle flows as low as 0.25 Mgal/d (1.0 MLD) and multiple units can be provided to handle virtually any flow
- » Turndown ratios for a standard design unit are 4:1 from peak to average flow. Note: ratios in excess of 15:1 can be accommodated
- » For larger applications, typically flows over 10 Mgal/d (37.5 MLD), the specialized internal components can be mounted in a concrete chamber

### How it Works

Flow is introduced into the Grit King® via a tangentially positioned inlet causing a rotational flow path around the dip plate. The flow spirals down the wall of the chamber as solids settle out by gravitational forces and forces created by the rotating flow (green arrow). The grit collects in the grit pot as the center cone directs flow away from the base, up and around the center shaft into the inside of the dip plate (blue arrow).

The upward flow rotates at a slower velocity than the outer downward flow. The resulting “shear” zone scrubs out the finer particles. The concentrated grit underflow is pumped or gravity fed to a grit classifier for dewatering (yellow arrow). The result is clean dewatered grit with low organic content.

### Grit King® Flow Pattern

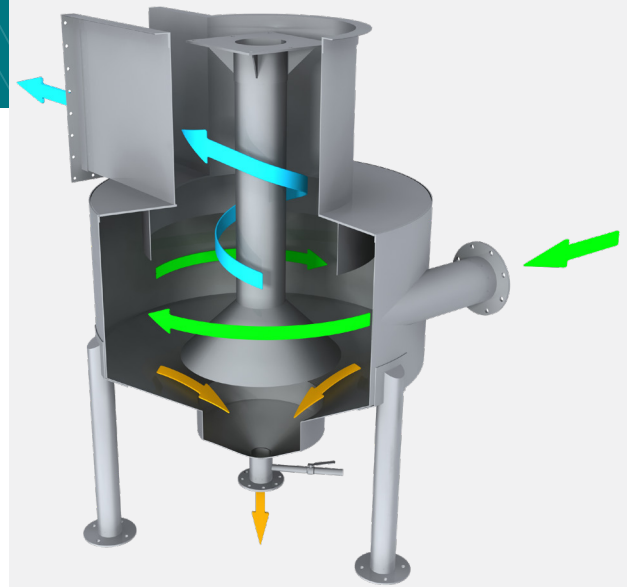

### Applications

- » New wastewater treatment plants
- » Treatment plant retrofits
- » Sediment removal pretreatment for potable water
- » Grit removal for industrial effluent
- » Pre-treatment for MBR and many other process upgrades
- » Grit separation in collection system

### Benefits

- » No moving parts
- » No external power source
- » Economical to own and operate
- » Compact design
- » Minimal headloss



## Configurations

- » The Grit King® is available as either a free standing or in-situ unit for versatile installation.
- » Multiple inlet and outlet configurations are available. The inlet and overflow channel may be rotated 360 degrees about the central axis. Overall elevations can be varied to accommodate local site conditions.

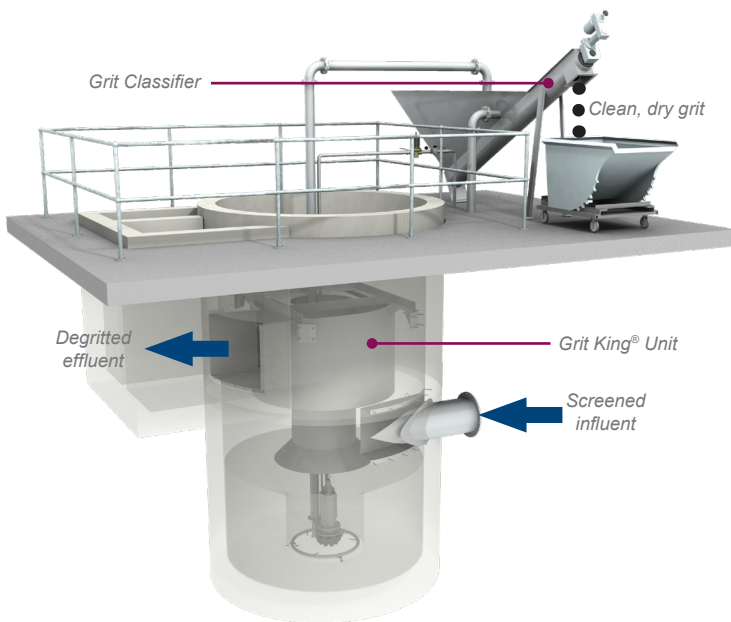
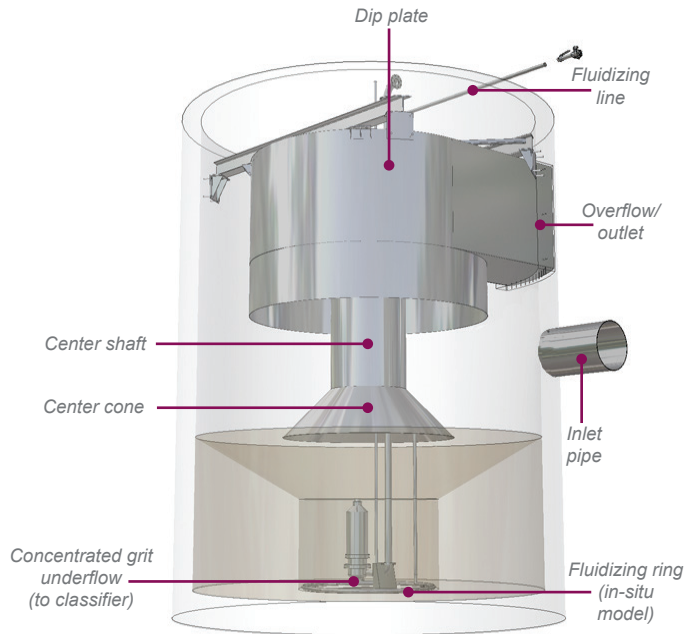

*In-Situ Grit King® and Classifier System*

## Design Notes

- » All-hydraulic design with no moving parts ensures a long product life
- » Internal flow structuring components create a long flow path aiding settlement and maximizing grit capture
- » 304 or 316 stainless steel

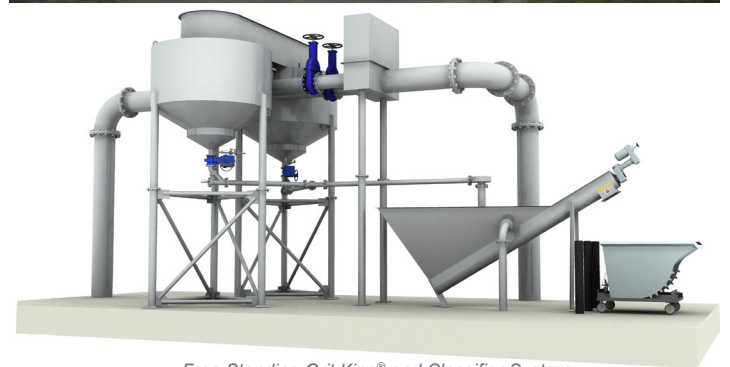

*Free Standing Grit King® and Classifier System*

**Hydro International**

**Oldcastle Infrastructure**  
A CRH COMPANY

📍 Hydro International  
2925 NE Alcock Suite 140 | Hillsboro, OR 97124  
☎ Tel: (866) 615-8130  
✉ Email: questions-AWW@oldcastle.com  
🌐 Web: www.hydro-int.com

### Learn more

Visit our website to learn how Grit King® grit separation will protect your plant, reduce your operational costs, and improve the performance of your entire plant.

→ [hydro-int.com/GritKing](http://hydro-int.com/GritKing)