

SpiraSnail® Compact

Small Footprint Grit Dewatering Classifier

Product Summary

Space efficient grit dewatering designed to fit your plant layout.

The SpiraSnail® Compact is a high efficiency grit dewatering unit that captures and dewateres fine grit, sugar sand, silt, snail shells, and high density fixed solids. When combined with the HeadCell® or Grit King® separator it provides a complete high performance fine grit removal system.

Performance

- » Designed for 95% capture of all grit 106 µm and larger
- » Guaranteed 95% capture of all grit 75 micron and larger when paired with the OpTeaCup™ grit concentrator

Capacity

- » 125 gpm (7.9 L/s) design flow capacity
- » 0.75 yd³/hr (0.6 m³/hr) conveying capacity

How it Works

Feed is pump or gravity fed from a Hydro International grit separator or washer. Flow enters from the top of the system into a deflector which directs the flow into the clarifier, away from the effluent weir. Water travels across the clarifier area while grit settles to the bottom.

Once grit has been removed, clarified water passes over a low velocity weir which prevents fine grit from bypassing and entering downstream processes. The clarified water is sent back into the wastewater stream.

After reaching the clarifier bottom, grit is conveyed by a slow rotating screw. The grit is dewatered while it is transported towards the discharge chute to be deposited in the grit receptacle, ready for disposal.

Design Notes

- » All Stainless Steel heavy-duty design ensures long product life
- » Optional explosion proof motor
- » Control panel VFD allows easy speed adjustment
- » System is only used for dewatering which minimizes turbulence and allows slower auger speeds and intermittent operation

SpiraSnail® Compact Cutaway

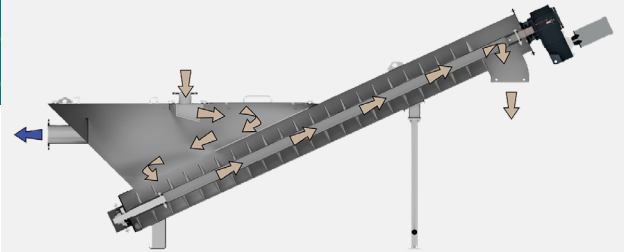

Applications

- » Grit dewatering for new, expanding, and upgrading at smaller WWTP
- » Replacement for worn out / ineffective grit dewatering equipment
- » Ideal for plants with space limitations

Benefits

- » Clarifier designed to optimize settling and reduce velocity
- » Shafted, self-bedding screw eliminates need for maintenance intensive wear bars or liners
- » Easily accessible external lower bearing with a gasketed cover provides easy maintenance and eliminates the risk of leaking if bearing fails
- » No plant water required to operate
- » Large internal clearances and removable access hatches simplify maintenance
- » Smaller in height, width, and length than many conventional grit classifiers allows the system to fit in places others can't



Innovative Clarifier Design

With its unique design, the clarifier on the SpiraSnail® Compact optimizes the settling tank characteristics and grit capture. Built on the same design principles found in all Hydro products where retention time and surface overflow rate are key criteria, the influent baffle forces flow to travel across the full clarifier area. The screw is protected by a cover which prevents wash out of fine grit.

Efficient Dewatering Design

Most classifiers and grit washers are incapable of retaining fine grit particles due to the use of an undersized clarifier tank or rapidly turning screw. The SpiraSnail® Compact has been designed to address these weaknesses. The innovative clarifier design provides increased surface area while the shallow incline and slow screw speed (2 rpm) allows 95% capture of 106 µm and larger grit particles.

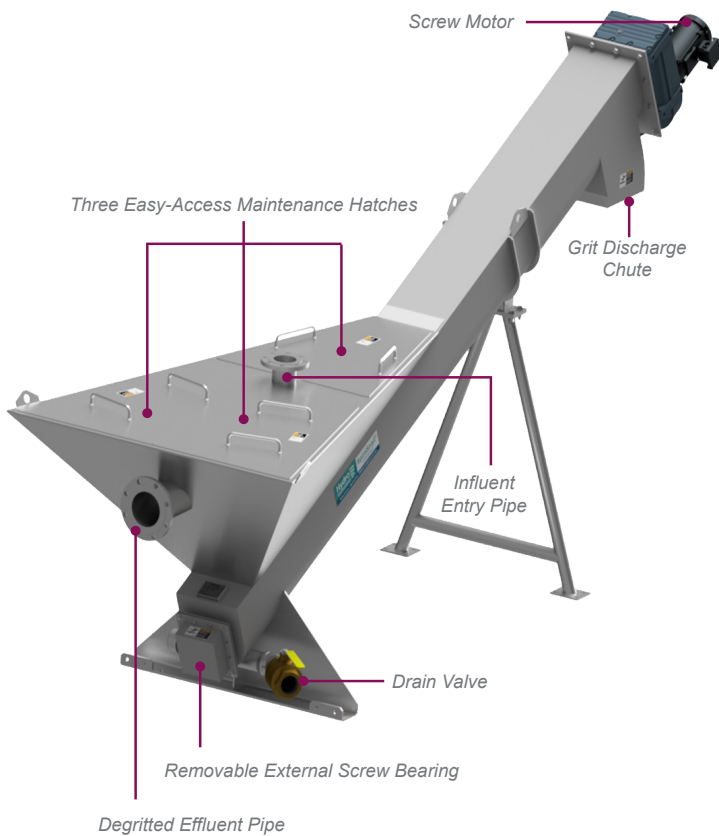

Screw and Bearing Improvements

The SpiraSnail® Compact uses a shafted screw design with an external lower bearing. Unlike classifiers with shaftless screws there is no need for liners or steel wear bars that are difficult to replace, typically requiring a complete disassembly of the unit. Instead, the SpiraSnail® Compact is equipped with a long lasting 4-bolt lower bearing that can be accessed and serviced from the outside of the screw trough saving both money and downtime.

OpTeaCup™ & SpiraSnail Compact System

For larger plants with higher capacities a grit concentrator may be needed to reduce volume. The OpTeaCup™ grit concentrator reduces influent to the SpiraSnail® Compact to < 20 gpm which improves performance to 95% capture of 75 µm and larger grit particles.

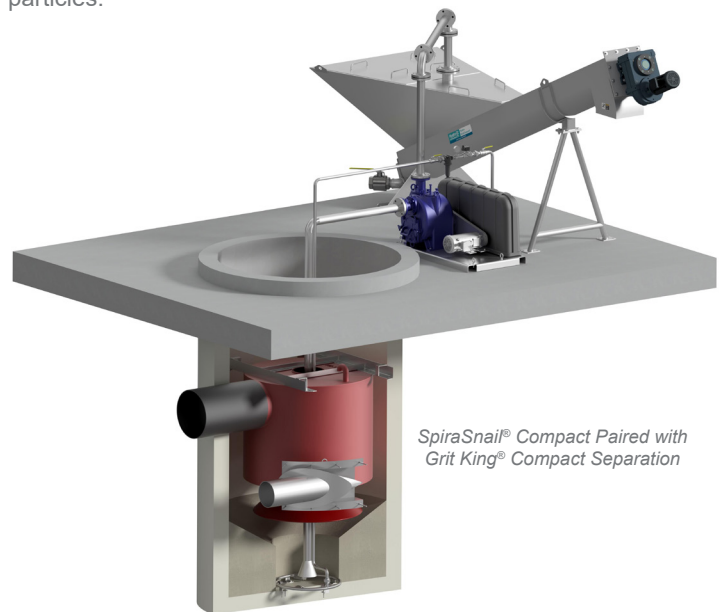

Hydro
International

Oldcastle
Infrastructure
A CRH COMPANY

📍 Hydro International
2925 NE Alcock Suite 140 | Hillsboro, OR 97124
☎ Tel: (866) 615-8130
✉ Email: questions-AWW@oldcastle.com
🌐 Web: www.hydro-int.com

Learn more

Visit our website to learn how SpiraSnail® Compact grit dewatering will protect your plant, reduce your operational costs, and improve the performance of your entire plant.

→ [hydro-int.com/Compact](https://www.hydro-int.com/Compact)